



# HANDLING EQUIPMENT

product overview

**VARIOfit**<sup>®</sup>

The perfect form of transport



# Contents



## VARIOfit® Catalog Download

Additional articles, Spare parts, Presentationtrolley	<b>9 - 12</b>
Platform trolleys, Box trolleys, ESD - trolleys, Dead man's handle, Table trolleys, Shelf trolleys, Serving trolley, Order-picking trolley, Document trolleys	<b>13 - 44</b>
Workshop trolleys, Table trolleys with pan	<b>45 - 53</b>
Sheet-material truck, -stand, -trolley, Workpiece-, Order-picking-, Carrier spar-, Euro container trolleys	<b>54 - 62</b>
Small order-picking trolleys, Material stands, Table transporter, Push-handle dollies, System dollies	<b>63 - 67</b>
Crate dollies, Long-goods trolley / dolly	<b>68 - 69</b>
Tyrehandling, Steel- / Aluminium trucks, Steel-cylindertruck -/trolley, Parcel trucks, Newspaper truck	<b>71 - 87</b>
Drumhandling, Drip trays, Cleaning trolley, Stacking frame with drip tray, Waste collection stand, Roll stand, Roll truck, Self-tipper	<b>88 - 95</b>
Hand trucks, Trailers, Two-wheeled platforms, Steel-frame dollies for pallets, Add-on frame for pallet dolly	<b>96 - 105</b>
Pallet converters	<b>106 - 114</b>
Dollies, Dollies collector, Triple-Dogs, Dollies Europa	<b>115 - 117</b>
Bridge plate / Ramp	<b>118 - 119</b>



## All parts, all makes

### TVH PARTS

**TVH Parts** is your one-stop shop for material handling, industrial and agricultural equipment parts and accessories.

Be amazed by our extensive range of attachments and internal transport equipment. In addition to the own brands such as TotalSource®, CAM System® and Energic Plus®, TVH has also entered into partnerships with top quality brands.

You are sure to receive the best service, and a guaranteed delivery within 24/48 hours.

### TVH EQUIPMENT

**TVH Equipment** consists of 3 activities: Sales, Rental and Service. The Sales Division deals in new and second-hand lift trucks and aerial work platforms.

With its short- and long-term rental of forklifts and aerial work platforms, the Rental Division is mainly active in Belgium. Additionally, our Service Division provides specialist support both in the field and in our own workshop.





# good reasons for **VARIOfit**



## Modular system

Four basic platforms of different sizes form the base for sturdy bolt-on fitting of almost all superstructures. **VARIOfit**® products bearing this symbol allow trouble-free modification to cater for changed requirements. This keeps **VARIOfit**® affordable for the customer and ensures that it maintains its value.



## Special orders!

**VARIOfit**®, as the name suggests, stands for unusually variable trucks and trolleys. In addition to its special product variants, **VARIOfit**® offers virtually unlimited possibilities for modification to suit customers' individual wishes.

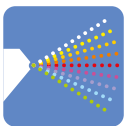

## Powder coating

After thorough preliminary treatment, **VARIOfit**® products are powder coated, then stove enamelled to optimise and enhance their surface finish. This makes them resistant to impacts and scratches and gives them the robustness they need for a long service life.



## Easy-running wheels

with wheel brakes and castor foot guards: Thanks to their new wheels with thermoplastic tyres, **VARIOfit**® trucks and trolleys leave no marks even on light-coloured floors. Their sealed precision ball bearings of deep-groove design are not only robust and impact-resistant, but also extremely easy-running. And it goes without saying that their swivel castors are equipped with wheel brakes and foot guards as required by EU standards.



## Innovative L-section frames

Only **VARIOfit**® trucks have the L-section frame developed exclusively by Cordes to ensure maximum load-bearing capacity. This specially designed frame makes Variofit trucks and trolleys extremely robust and light.



## TÜV mark

TÜV (the German technical inspection authority) stands for quality and safety. Most **VARIOfit**® products bear this mark. The TÜV mark can be awarded to trolleys with a payload of up to 500 kg and trucks with a capacity of 250 kg.



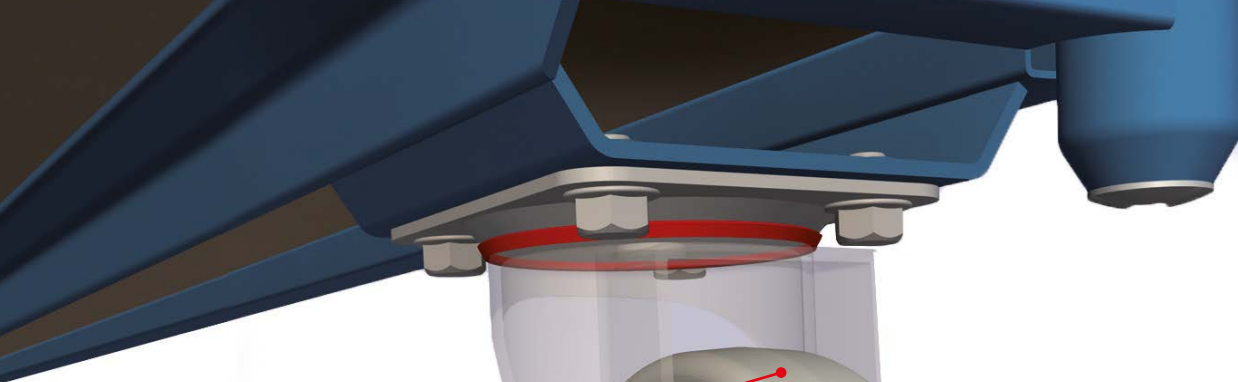

**Running surface:**

Grey, non-chalking thermoplastic rubber.

**Thread guard:**

Minimises uptake of threads lying on the floor.

**Foot guard:**

Standard equipment, of course.

**Long life:**

Sealed precision deep-groove ball bearings.

**Easy-runner wheel:**

About 50% less initial and rolling resistance.

# Easy runners, distance **no problem**

With their maintenance-free precision deep-groove ball bearings and optimised tyres, these **VARIOfit®** wheels offer about 50% less initial resistance than normal castors. So the truck is easy to start moving even when heavily loaded. This saves time, money and effort in day-to-day use. And of course only **VARIOfit®** supplies them as standard with the **VARIOfit®** foot guard.

Conventional wheels need a lot of strength to set the truck in motion and keep it moving.



The **VARIOfit®** Easy-runner wheels need a minimum of effort to get the truck moving, even when heavily loaded. That also means less effort when pushing and reduces materials handling times.

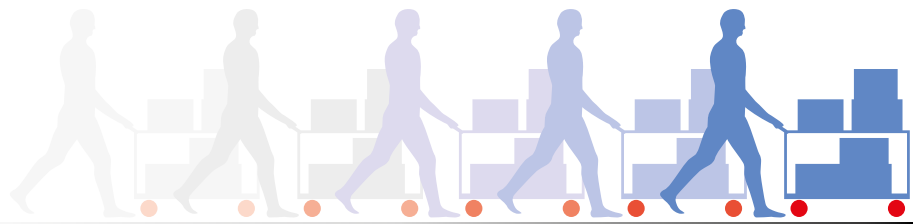

Combined with **EasySTOP**, the perfect solution





# Dead man's brake

On pages 34, 35 and 85 you will find products with our **VARIOfit®** dead man's brake



- Convenient handling
- Safe steering with brake released
- Stops instantly if push-/ pull-bar is released
- Braking possible in all wheel positions
- Firm standing
- No danger of injury due to exposed Bowden cables or protruding metal edges
- Adjustable braking strength



# Central foot brake

All **VARIOfit®** items marked with  Button are fitted with **EasySTOP** central brake system as standard. **No Surcharge!**



### Wheelsize

REF	Wheel diam.
	mm
161TA6420	125
161TA6421	160
161TA6422	200

Order numbers for relevant wheel sizes

- **Easy stop:** Simply press the EasySTOP brake once – this arrests both swivel castors.
- **Easy go:** Return the pedal to its starting position – quick and easy.
- **Safety:** Fixed position with easy access by trolley operator permits instant braking
- **Adjustable braking action**
- Pedal can be operated with normal shoes or safety footwear
- Braking always possible regardless of wheel position
- **Ergonomic:** Light actuation, short travel
- **Compatible:** Available for most types of castor in common use





# Wheel types / layouts



**Plain bearing:**  
**Simple, largely maintenance-free bearing.** Impact-resistant. Polyamide bushing. Suitable for operation in wet conditions. For low-speed trucks and trolleys.

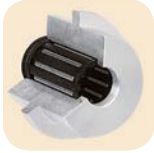

**Roller bearing:**  
**Robust, sturdy, largely maintenance-free bearing.** Low bearing friction. Impact-resistant. Permanent lubrication. The most widely used bearing for low-speed trucks and trolleys.



**Deep-groove ball bearing:**  
**Precision ball bearing, easy-running, even with heavy loads and at higher speeds.**



Swivel castors with top plates,



bolt-hole castors

**What is a castor?**  
**A castor consists of at least one wheel, a fixed or swivelling fork, an axle and a means of attachment (e.g. to a truck or trolley).** There are four basic types of castors. Swivel castors with top plates, fixed castors with top plates, bolt-hole castors, and swivel castors with spigot.



**Two swivel and two fixed castors**  
- Commonest layout  
- good directional stability  
- good cornering

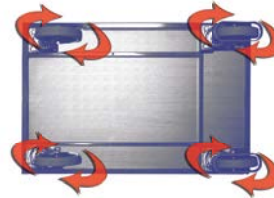

**Four swivel castors**  
- Highly manoeuvrable, suitable for cramped conditions  
- improved directional stability thanks to lockable swivel castors

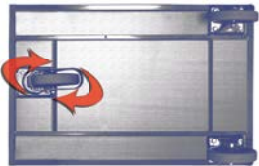

**One swivel and two fixed castors**  
- Suitable for light loads  
- highly manoeuvrable  
- tends to tip if load concentrated at front

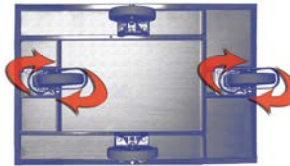

**Two swivel and two fixed rollers, rhombic layout**  
- Fixed castors are slightly higher  
- good directional stability  
- tends to tip if load concentrated at corners

Pneumatic wheel		Polyamide wheel		Solid-rubber wheel	
	Suitable for uneven ground, e.g. with differences in level, especially outdoors.		For use on level ground in wet areas.		Recommended for heavy loads even on poor ground and with sensitive payloads.
- Roller bearing - low carrying capacity - good ride comfort - abrasion-resistant		- Roller bearing - high carrying capacity - resistant to chemicals (salts, fats, acids, alkalis)		- Deep-groove ball bearing - high carrying capacity - low noise - low rolling resistance - high wear-resistance	
Electrostatic discharge wheels (ESD)			Polyurethane wheels		
	Suitable where there is a need to prevent static charging of the trolley and payload.	For use in the industrial sector with heavy loads and for mixed indoor/outdoor applications. Polyurethanes can be selected specifically for your field of application.			
			<b>96° Shore</b> Particularly suitable in high-friction situations, e.g. for motorised trolleys.		<b>92° Shore</b> Suitable for high-stress situations on rough ground, e.g. thresholds and outdoor areas.
		- Deep-groove ball bearing - high carrying capacity - low noise - high abrasion resistance - high cut resistance - low rolling resistance - high wear resistance		- Deep-groove ball bearing - high carrying capacity - low noise - high abrasion resistance - high cut resistance - low rolling resistance - high wear resistance	

# Additional articles



**Accessories to catalogue programme. The prices shown are the additional price when ordered with articles from the catalogue. Prices when ordered separately available on request. Additional prices for wheels are for 1 set = 4 wheels instead of standard wheels (solid rubber).**



Even the standard **VARIOfit®** wheels with grey thermoplastic tyres cater for a wide range of applications. They are suitable for a variety of surfaces and are resistant to a large number of aggressive substances (e.g. numerous oils, gases, acids, solvents and organic substances).



**Pneumatic wheels (Caution: lower carrying capacity) Set**

REF	Load cap.	Wheel diam.
	kg	mm
161TA6346	150 kg	150 instead 125 SR*
161TA6245	225 kg	200 instead 160, 200 SR*
161TA6249	390 kg	230 instead 160, 200 SR*



**Polyamide wheels set**

REF	Wheel diam.
	mm
161TA6347	125
161TA6348	150
161TA6349	200



**Elastic-solid-rubber wheels set**

REF	Wheel diam.
	mm
161TA6350	125
161TA6351	160
161TA6352	200



**Electrically conductive solid-rubber wheels (ESD) set**

REF	Wheel diam.
	mm
161TA6353	125
161TA6354	160
161TA6355	200



**Polyurethane wheels set (96° Shore)**

REF	Wheel diam.	Load cap.
	mm	kg
161TA6647	200	1050



**Polyurethane wheels set (92° Shore)**

REF	Wheel diam.	Load cap.
	mm	kg
161TA6646	200	1050



**Revolving buffers suitable for narrow passages, e.g. to protect walls from damage, scratches etc. 100 mm diameter, light grey plastic. This increases the overall width by 70 mm. 1 set = 4 buffers. Not adjustable - through as ex-factory equipment. Cannot be retrofitted**

REF	Dimension
	mm
161TA6266	100 x 24 mm



**Galvanised steel load surface: galvanised steel sheet, folded over load surface**

REF	for Loading surface
	mm
163TA7961	850 x 500
163TA7962	1000 x 600
161TA6273	1000 x 700
161TA6275	1200 x 800



**Plastic load surface, abrasion-resistant surface, weather-resistant, resistant to oil and most acids, recyclable.**

REF	for Loading surface
	mm
163TA7962	850 x 500
163TA7962	1000 x 600
161TA6274	1000 x 700
161TA6276	1200 x 800



**Clipboard: Wood with paper grip and pencil holder. Attached by tube clamps.**

REF	Format
	Din
161TA6265	A4 high
161TA6267	A4 transversely



**Protective strip made of plastic profile, attached around the basic frame. Protects door frames and walls from damage, scratches etc. Cannot be retrofitted**

REF	High
	mm
161TA6268	30

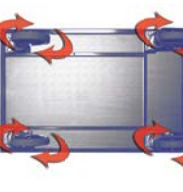

**4 Swivel castors**

REF		
161TA6238	TR	This makes the trolley highly manoeuvrable, it can turn on the spot.
163TA7965	P	
163TA7966	ER	

TR = Thermoplastic rubber tyres,  
P = Pneumatic wheels  
ER = Elastic-solid-rubber wheels

resistant rollers (see above)	aluminium versions	available with Puncture-proof wheels (optional)
can be upgraded with pegboard tool panel	also available with central foot brake (optional)	fitted with dead man's brake
lockable	delivered knocked down	Video on <a href="http://www.VARIOfit.eu">www.VARIOfit.eu</a>
QR - Code	ESD EN 61340	New in <b>VARIOfit®</b> programme



Central foot brake  
REF 161TA6420



Pegboard tool panel for  
workshop trolley  
REF 161TA6598

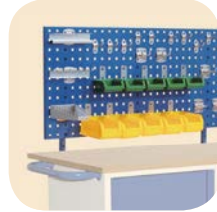

Drawer divider set  
REF 161TA6616



Material crate  
REF 161TA6405



Plastic crate  
REF 161TA6398



Outlet cock  
REF 161TA6701



Holder selection  
REF 161TA6600

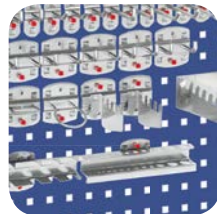

Hang-on wire basket  
REF 161TA6743



# Additional articles

## Wheelsize

REF	Wheel diam.
	mm
161TA6420	125
161TA6421	160
161TA6422	200

Order numbers for relevant wheel sizes

We equip your **VARIOfit**® item with **EasySTOP** the new central brake system. Articles marked with  can be combined with the brake system.

## Pegboard tool panel for workshop trolley, for Article on Pages 46 - 48

REF	Dimension	for Workshop trolley
	mm	
161TA6598	1000 x 450	... with border
161TA6599	1000 x 450	... without border

## Drawer divider set, for the pages 28, 46 - 50

REF	Weight	
	kg	
161TA6370	2,5	pages 51
161TA6616	1,5	pages 47

## Material crate, page 46, 56

REF	Size	Color
	mm	
161TA6405	230 x 140 x 130	red
161TA6406	290 x 140 x 130	blue
161TA6399	85 x 105 x 45	green
161TA6400	160 x 105 x 75	yellow

## Plastic crate, Page 62

REF	Dimension	Load cap.
	mm	l
161TA6397	600 x 400 x 220	45
161TA6398	600 x 400 x 170	35

## Outlet cock for Articles from page 53, 92, 93, 95

REF	
161TA6701	Outlet cock, for draining liquids for articles with sheet-steel trough as ex-factory equipment

## Holder selection, page 46

REF	
161TA6600	18-parts
161TA6601	28-parts

## Hang-on wire basket, page 16

REF	Dimension			Weight
	a	b	c	kg
161TA6743	520	200	230	2,5

for existing horizontal or vertical tube

# Spare parts



## Safety handles

REF
161TA6632



Safety handles  
REF 161TA6632

## Plastic skids

REF	
161TA6778	REF 137TA1768, 161TA6378, 137TA1773, 137TA1776 REF 137TA1794, 137TA1798, 137TA1802, 161TA6379



Plastic skids  
REF 161TA6778

## plastic cap for truckwheel

REF	Ø
161TA6625	mm 117



plastic cap  
REF 161TA6625

- moves 30% easier
- groove profile absorbs less dirt
- low noise moving profile

## pneumatic tyres for all trucks

REF	Wheel diam.
	mm
161TA6633	260 x 85

incl. fixing parts



pneumatic tyres  
REF 161TA6633

## puncture-proof tyres for all trucks

REF	Wheel diam.
	mm
161TA6634	260 x 85

incl. fixing parts

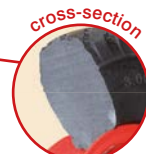

puncture-proof tyres  
REF 161TA6634

## solid-rubber tyres for all trucks

REF	Wheel diam.
	mm
163TA7881	250 x 60

incl. fixing parts



solid-rubber tyres  
REF 163TA7881

Additional carrying bars for all trucks  
on page 74 up to 84 available.

## Additional carrying bar for trucks

REF	Weight	Length	
	kg	mm	
136TA1011	3,0	850	carrying bar

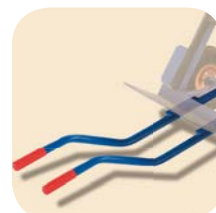

carrying bars  
REF 136TA1011

## Gas pressure spring

REF	Version	
161TA6777	new	only for wheeltrucks
161TA6630	old	only for wheeltrucks

incl. fixing parts



Gas pressure spring



# our presentation trolley

available in 4 languages

**VARIOfit**  
The perfect form  
of transport

We have fitted out a **VARIOfit**® shelf trolley to give you at least a small idea of the huge range of **VARIOfit**® products. You will be impressed by the great variety of sack trucks. Experience our **EasySTOP** braking system and the smoothness of the precision deep-groove ball bearings used in our wheels. Read all about the thermoplastic wheels that you can find under many of our **VARIOfit**® products. Our trolley also contains a selection of the proven Cordes solutions for storage and transport of bulky goods. We will be glad to supply a presentation trolley for your showroom. Just call us.

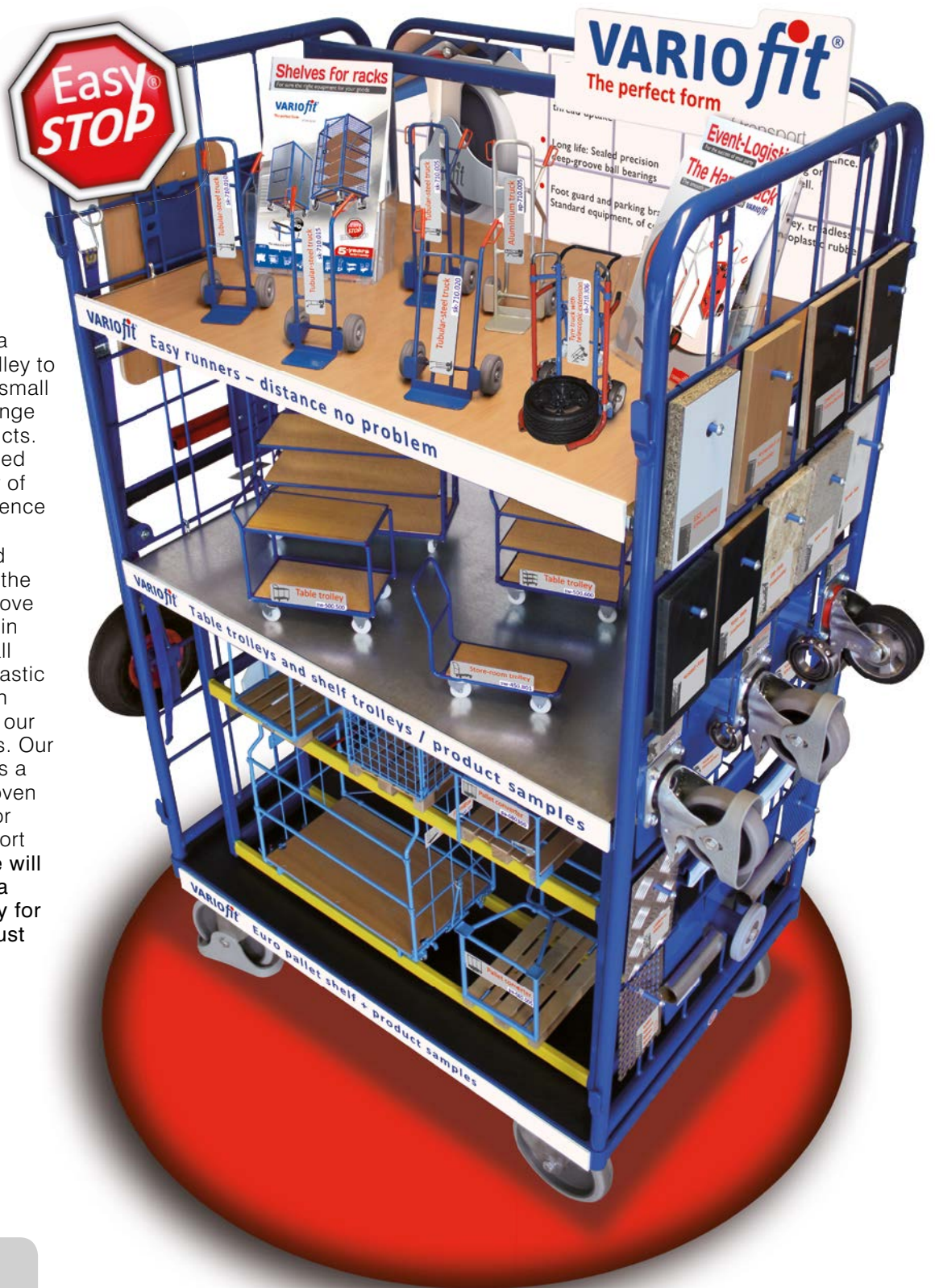

by **VARIOfit**®



## Store-room trolleys



## Platform trolleys



VARIOfit®







optional

# Basic platform trolleys / tubular steel pushbar trolleys



Basic platform trolley  
REF 120TA9757



Pushbar trolley  
REF 120TA9758



Pushbar trolley  
REF 120TA9764



Double-end pushbar trolley  
REF 120TA9766

## Basic platform trolleys / tubular steel pushbar trolleys

Modular system; Base structure with innovative frame section; Load surface of wood-based board, surface finish beech; Trolley powder-coated RAL 5010 gentian blue; permanent surface protection; impact-resistant and scratch-resistant; Grey non-marking thermoplastic rubber tyres with precision deep-groove ball bearings; thread guard and foot guard; 2 swivel castors with wheel brakes and 2 fixed castors

### Basic platform trolleys

REF	Dimension			Loading surface		Weight kg	Load cap. kg	Wheel diam. mm
	a	b	c	d	e			
120TA9757	910	500	250	910	500	20,5	400	160
161TA6169	1060	600	290	1060	600	25,0	500	200
120TA9759	1060	700	290	1060	700	26,0	500	200
120TA9760	1260	800	290	1260	800	31,0	500	200

Swivel castors with wheel brakes and foot guards for your safety.



### Pushbar trolleys

REF	Dimension			Loading surface		Weight kg	Load cap. kg	Wheel diam. mm
	a	b	c	d	e			
120TA9758	975	500	966	880	500	24,0	400	160
147TA3373	1125	600	1006	1030	600	28,5	500	200
120TA9762	1125	700	1006	1030	700	30,0	500	200
120TA9763	1325	800	1006	1230	800	34,5	500	200

Swivel castors with wheel brakes and foot guards for your safety.



### Pushbar trolleys

REF	Dimension			Loading surface		Weight kg	Load cap. kg	Wheel diam. mm
	a	b	c	d	e			
120TA9764	975	500	927	880	500	20,5	250	125
120TA9765	1125	600	927	1030	600	24,0	250	125

Swivel castors with wheel brakes and foot guards for your safety.



### Double-end pushbar trolleys

REF	Dimension			Loading surface		Weight kg	Load cap. kg	Wheel diam. mm
	a	b	c	d	e			
120TA9766	1040	500	927	850	500	25,0	250	125
120TA9767	1190	600	927	1000	600	29,0	250	125

Swivel castors with wheel brakes and foot guards for your safety.

# Folding pushbar trolleys



## Folding pushbar trolleys

Welded steel construction; folding pushbar; Load surface of wood-based board, surface finish beech; Trolley powder-coated RAL 5010 gentian blue; permanent surface protection; impact- and scratch-resistant; Grey non-marking thermoplastic rubber tyres with precision deep-groove ball bearings; thread guard and foot guard; 2 **EasySTOP** swivel castors and 2 fixed castors



See page 35 for folding pushbar trolley with maximum-safety dead man's brake



### Folding pushbar trolleys

REF	Dimension			Loading surface		Weight	Load cap.	Wheel diam.
	mm			mm				
	a	b	c	d	e	kg	kg	mm
120TA9807	820	470	936	720	450	16,0	150	125
120TA9808	1000	620	975	900	600	24,0	250	160

EasySTOP swivel castors and foot guards for your safety.

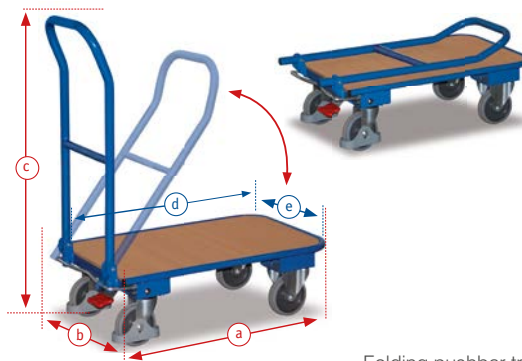

Folding pushbar trolley REF 120TA9807

### Folding trolley with 2 pushbars

REF	Dimension			Loading surface		Weight	Load cap.	Wheel diam.
	mm			mm				
	a	b	c	d	e	kg	kg	mm
121TA1370	855	470	936	720	450	23,0	150	125

EasySTOP swivel castors and foot guards for your safety.

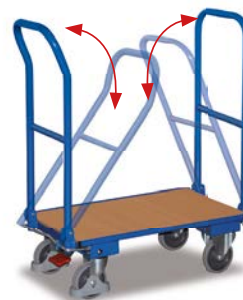

Folding trolley with 2 pushbars REF 121TA1370

### Folding trolley with 2 pushbars

REF	Dimension			Loading surface		Weight	Load cap.	Wheel diam.
	mm			mm				
	a	b	c	d	e	kg	kg	mm
161TA6677	1035	620	975	900	600	33,0	250	160

EasySTOP swivel castors and foot guards for your safety.

All our folding pushbar trolleys have no protruding edges on the load surfaces and can therefore be loaded beyond the edge.

### Folding pushbar trolley with 2 shelves

REF	Dimension			Loading surface		Weight	Load cap.	Wheel diam.
	mm			mm				
	a	b	c	d	e	kg	kg	mm
163TA7967	855	470	936	720	450	26,0	150	125

EasySTOP swivel castors and foot guards for your safety.



Folding pushbar trolley with 2 shelves REF 163TA7967

### Aluminium folding pushbar trolley

Welded aluminium construction; folding pushbars and shelf; upper shelf lockable in folded state; lower load surface also usable with shelf folded; load surface of diamond-tread plate; grey, non-marking thermoplastic rubber tyres with precision deep-groove ball bearings; thread guard and foot guard; 2 swivel castors with **EasySTOP** and 2 fixed castors.

### Aluminium folding pushbar trolley with 2 shelves

REF	Dimension			Loading surface		Weight	Load cap.	Wheel diam.
	mm			mm				
	a	b	c	d	e	kg	kg	mm
163TA7968	855	470	936	720	450	17,0	150	125

EasySTOP swivel castors and foot guards for your safety.



Aluminium folding pushbar trolley with 2 shelves REF 163TA7968

### Aluminium folding pushbar trolleys with diamond-tread load surface

REF	Dimension			Loading surface		Weight	Load cap.	Wheel diam.
	mm			mm				
	a	b	c	d	e	kg	kg	mm
120TA9809	820	450	936	720	450	11,0	150	125
120TA9810	995	600	985	900	600	19,0	150	160
161TA6677	995	600	985	900	600	19,0	250	160

EasySTOP swivel castors and foot guards for your safety.



Aluminium folding pushbar trolley REF 120TA9809



# C+C trolleys

## C+C trolleys

Trolley nestable; Load surface of wood-based board, surface finish beech or waterproof bonded plywood, surface finish screen printed, anti-slip; Trolley powder-coated RAL 5010 gentian blue; permanent surface protection; impact- and scratch-resistant; Grey non-marking thermoplastic rubber tyres with precision deep-groove ball bearings; thread and foot guard; 2 swivel castors with wheel brakes and 2 fixed castors

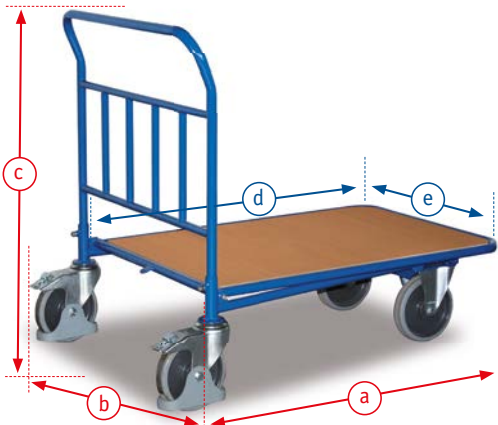

C+C trolley  
REF 163TA7882



Hang-on wire basket, page 10

### C+C trolleys

REF	Dimension			Loading surface		Weight	Load cap.	Wheel diam.
	mm			mm				
	a	b	c	d	e			
163TA7882	992	645	965	880	500	26,0	400	160
163TA7883	1142	845	1005	1030	700	37,0	500	200

Swivel castors with wheel brakes and foot guards for your safety.



### C+C trolleys with load surface of waterproof bonded plywood, surface finish screen printed

REF	Dimension			Loading surface		Weight	Load cap.	Wheel diam.
	mm			mm				
	a	b	c	d	e			
161TA6441	992	645	965	880	500	28,0	400	160
161TA6466	1142	745	1005	1030	600	32,5	500	200
161TA6492		845	1005	1030	700	35,0	500	200

Swivel castors with wheel brakes and foot guards for your safety.



C+C trolley  
REF 161TA6441



### C+C trolleys with 2 load surfaces of waterproof bonded plywood, surface finish screen printed

REF	Dimension			Loading surface		Weight	Load cap.	Wheel diam.
	mm			mm				
	a	b	c	d	e			
161TA6442	992	645	965	880	500	39,5	400	160
161TA6467	1142	745	1005	1030	600	47,5	500	200
161TA6493	1142	845	1005	1030	700	51,5	500	200

Swivel castors with wheel brakes and foot guards for your safety.



C+C trolley  
REF 161TA6442



### C+C trolleys with load surface of waterproof bonded plywood, surface finish screen printed, and 4 side frames

REF	Dimension			Loading surface		Weight	Load cap.	Wheel diam.
	mm			mm				
	a	b	c	d	e			
161TA6443	950	645	955	880	447	31,5	400	160
161TA6468	1100	745	995	1030	547	35,5	500	200
161TA6494	1100	845	995	1030	647	38,0	500	200

Swivel castors with wheel brakes and foot guards for your safety.



C+C trolley  
REF 161TA6443



# Trolley bay starter unit for C+C trolley



## Trolley bay starter unit for C+C trolleys

Welded tubular steel; Surface hot galvanised; Including initial chain for coin lock; Rows can be extended by adding accessories; Suitable for all standard C+C trolleys

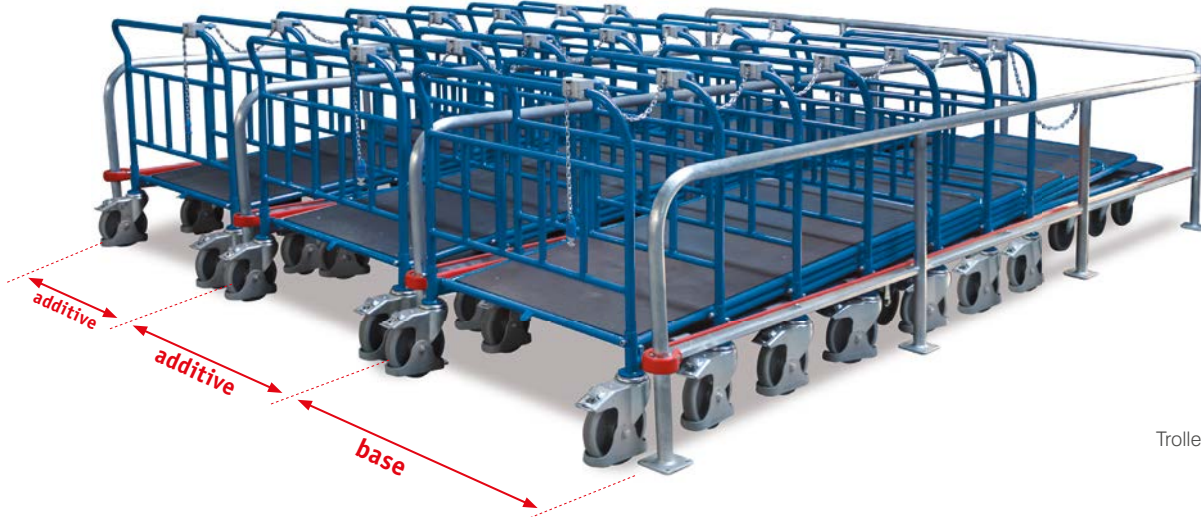

Trolley bay starter unit for C+C trolleys  
REF 161TA6678

### Add-on row for starter unit

REF	Dimension			Loading surface	
	a	b	c	d	e
161TA6678	4000	710	800	3960	640
161TA6687	4000	810	800	3960	740
161TA6693	4000	910	800	3960	840

with 1 piece initial chain for coin lock

The following bay capacities are possible:  
approx. 10 C+C trolleys per row, load surface 880 x 500 mm  
approx. 9 C+C trolleys per row, load surface 1030 x 600 mm  
approx. 9 C+C trolleys per row, load surface 1030 x 700 mm

### Additional Articles

REF	Dimension			
	a	b	c	
161TA6714	4000	640	800	
161TA6721	4000	740	800	
161TA6722	4000	840	800	Add-on row for starter unit

with 1 piece initial chain for coin lock



Add-on row for starter unit  
REF 161TA6714



### C+C trolley security / coin lock with chain

REF	chain length
	mm
161TA6703	350

C+C trolley security  
REF 161TA6703



# Tubular steel pushbar trolleys / store-room trolleys



Tubular-steel pushbar trolley  
REF 138TA4022



Tubular-steel pushbar trolley  
REF 147TA3486



Tubular-steel pushbar trolley  
REF 138TA4025



Store-room trolley  
REF 138TA4019



Store-room trolley  
REF 138TA4021



## Tubular-steel pushbar trolleys

Modular system; Load surface of wood-based board, surface finish beech; Transverse strut in pushbar; Trolley powder-coated RAL 5010 gentian blue; permanent surface protection; impact- and scratch-resistant; Grey non-marking thermoplastic rubber tyres with precision deep-groove ball bearings; thread and foot guard; 2 swivel castors with wheel brakes and 2 fixed castors



optional

### Tubular-steel pushbar trolleys

REF	Dimension			Loading surface		Weight	Load cap.	Wheel diam.
	mm			mm				
	a	b	c	d	e			
138TA4022	950	500	966	850	500	21,5	400	160
138TA4023	1100	700	1006	1000	700	26,0	400	200
138TA4024	1300	700	1006	1200	700	30,0	400	200

Swivel castors with wheel brakes and foot guards for your safety.



optional

### Light version tubular steel pushbar trolleys with one horizontal tube

REF	Dimension			Loading surface		Weight	Load cap.	Wheel diam.
	mm			mm				
	a	b	c	d	e			
147TA3486	950	450	910	850	450	18,0	200	125
147TA3487	1100	600	910	1000	600	25,0	200	125

Swivel castors with wheel brakes and foot guards for your safety.



optional

### Tubular-steel pushbar trolleys

REF	Dimension			Loading surface		Weight	Load cap.	Wheel diam.
	mm			mm				
	a	b	c	d	e			
138TA4025	950	500	966	850	500	22,5	400	160
138TA4026	1100	700	1006	1000	700	27,5	400	200
138TA4027	1300	700	1006	1200	700	31,0	400	200

Swivel castors with wheel brakes and foot guards for your safety.

## Store-room trolleys

Robust welded steel or aluminium construction; Transverse strut in pushbar; Load surface of wood-based board; surface finish beech, or waterproof bonded plywood, surface finish screen printed, anti-slip. Steel store-room trolley powder-coated RAL 5010 gentian blue; permanent surface protection; impact- and scratch-resistant; Grey non-marking thermoplastic rubber tyres with precision deep-groove ball bearings; thread and foot guard; 2 **EasySTOP** swivel castors and 2 fixed castors

### Store-room trolleys of welded steel construction

REF	Dimension			Loading surface		Weight	Load cap.	Wheel diam.
	mm			mm				
	a	b	c	d	e			
138TA4019	1070	450	910	890	450	15,5	200	125
138TA4020	1220	600	910	1040	600	19,0	200	125

EasySTOP swivel castors and foot guards for your safety.

### Store-room trolleys of welded aluminium construction

REF	Dimension			Loading surface		Weight	Load cap.	Wheel diam.
	mm			mm				
	a	b	c	d	e			
138TA4021	1020	440	925	847	440	8,0	200	125

EasySTOP swivel castors and foot guards for your safety.



# System trolleys with board sides



## System trolleys with board sides

Modular system trolley; Base structure with innovative frame section; Load surface, end and side walls of wood-based board, surface finish beech. Trolley powder-coated RAL 5010 gentian blue, permanent surface protection, impactresistant and scratch-resistant. Grey non-marking thermoplastic rubber tyres with precision deep-groove ball bearings, thread guard and foot guard, 2 swivel castors with wheel brakes and 2 fixed castors

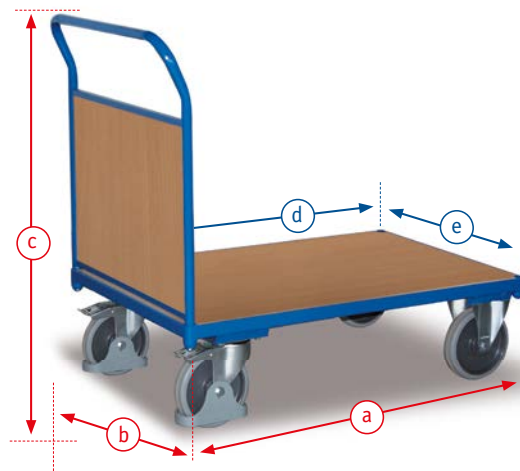

Single-end trolley  
REF 120TA9768

### Single-end trolleys

REF	Dimension			Loading surface		Weight	Load cap.	Wheel diam.
	a	b	c	d	e			
120TA9768	975	500	966	880	500	26,0	400	160
161TA6174	1125	600	1006	1030	600	31,0	500	200
120TA9769	1125	700	1006	1030	700	33,0	500	200
120TA9770	1325	800	1006	1230	800	38,0	500	200

Swivel castors with wheel brakes and foot guards for your safety.

### Double-end trolleys

REF	Dimension			Loading surface		Weight	Load cap.	Wheel diam.
	a	b	c	d	e			
120TA9771	1040	500	966	850	500	31,0	400	160
161TA6175	1190	600	1006	1000	600	37,0	500	200
120TA9772	1190	700	1006	1000	700	40,0	500	200
120TA9773	1390	800	1006	1200	800	45,0	500	200

Swivel castors with wheel brakes and foot guards for your safety.



Double-end trolley  
REF 120TA9771

### Three-sided trolleys, side wall removable

REF	Dimension			Loading surface		Weight	Load cap.	Wheel diam.
	a	b	c	d	e			
120TA9774	1040	500	966	850	476	36,5	400	160
161TA6176	1190	600	1006	1000	576	43,0	500	200
120TA9775	1190	700	1006	1000	676	45,5	500	200
120TA9776	1390	800	1006	1200	776	52,0	500	200

Swivel castors with wheel brakes and foot guards for your safety.



Three-sided trolley  
REF 120TA9774

### Four-sided trolleys, side walls removable

REF	Dimension			Loading surface		Weight	Load cap.	Wheel diam.
	a	b	c	d	e			
120TA9777	1040	500	966	850	452	41,5	400	200
161TA6177	1190	600	1006	1000	552	48,5	500	200
120TA9778	1190	700	1006	1000	652	51,0	500	200
120TA9779	1390	800	1006	1200	752	59,0	500	200

Swivel castors with wheel brakes and foot guards for your safety.



Four-sided trolley  
REF 120TA9777



# System trolleys with mesh sides



Single-end trolley  
REF 120TA9780

## System trolleys with mesh sides

Modular system; Base structure with innovative frame section and wood-based board, surface finish beech; Mesh side and end walls; mesh size 50 x 50; Trolley powder-coated RAL 5010 gentian blue; permanent surface protection; impact- and scratch-resistant; Grey non-marking thermoplastic rubber tyres with precision deep-groove ball bearings; thread guard and foot guard; 2 swivel castors with wheel brakes and 2 fixed castors

### Single-end trolleys

REF	Dimension			Loading surface		Weight	Load cap.	Wheel diam.
	mm			mm				
	a	b	c	d	e	kg	kg	mm
120TA9780	975	500	966	880	500	25,0	400	160
120TA9781	1125	600	1006	1030	600	29,5	500	200
120TA9782	1125	700	1006	1030	700	31,5	500	200
120TA9783	1325	800	1006	1230	800	36,5	500	200

Swivel castors with wheel brakes and foot guards for your safety.



Double-end trolley  
REF 120TA9784

### Double-end trolleys

REF	Dimension			Loading surface		Weight	Load cap.	Wheel diam.
	mm			mm				
	a	b	c	d	e	kg	kg	mm
120TA9784	1040	500	966	850	500	29,0	400	160
120TA9785	1190	600	1006	1000	600	34,5	500	200
120TA9786	1190	700	1006	1000	700	36,5	500	200
120TA9787	1390	800	1006	1200	800	42,0	500	200

Swivel castors with wheel brakes and foot guards for your safety.



Three-sided trolley,  
REF 120TA9788

### Three-sided trolleys, side wall removable

REF	Dimension			Loading surface		Weight	Load cap.	Wheel diam.
	mm			mm				
	a	b	c	d	e	kg	kg	mm
120TA9788	1040	500	966	850	476	33,0	400	160
120TA9789	1190	600	1006	1000	576	39,0	500	200
120TA9790	1190	700	1006	1000	676	41,0	500	200
120TA9791	1390	800	1006	1200	776	47,5	500	200

Swivel castors with wheel brakes and foot guards for your safety.



Four-sided trolley  
REF 120TA9792

### Four-sided trolleys, side walls removable

REF	Dimension			Loading surface		Weight	Load cap.	Wheel diam.
	mm			mm				
	a	b	c	d	e	kg	kg	mm
120TA9792	1040	500	966	850	452	37,5	400	160
120TA9793	1190	600	1006	1000	552	43,0	500	200
120TA9794	1190	700	1006	1000	652	45,5	500	200
120TA9795	1390	800	1006	1200	752	53,0	500	200

Swivel castors with wheel brakes and foot guards for your safety.

# Heavy-duty trolleys



## Heavy-duty trolleys

Base structure with innovative frame section; Load surface, side and end walls of waterproof bonded plywood, surface finish screen printed, anti-slip; Trolley powder-coated RAL 5010 gentian blue; permanent surface protection; impact- and scratch-resistant; Elastic on cast aluminium wheels with foot guard; ball-bearing hubs; 2 swivel castors with wheel brakes and 2 fixed castors

### Pushbar trolleys

REF	Dimension					Loading surface	Weight	Load cap.	Wheel diam.
	mm			mm					
	a	b	c	d	e				
137TA1899	1128	700	1006	1026	700	37,5	1000	200	
137TA1900	1328	800	1006	1226	800	43,0	1000	200	
137TA1901	1728	800	1006	1626	800	49,5	1000	200	
161TA6515	2128	800	1006	2026	800	60,5	1000	200	

Swivel castors with wheel brakes and foot guards for your safety.

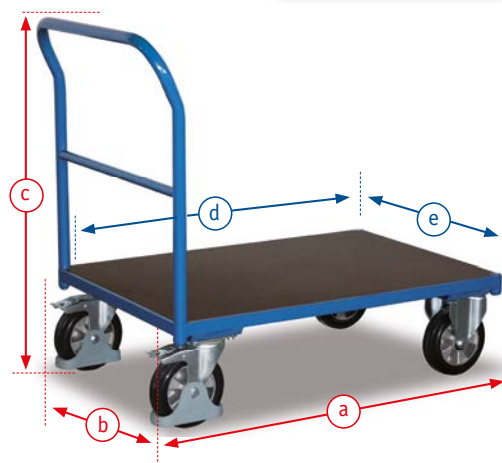

Pushbar trolley  
REF 137TA1899



Single-end trolley  
REF 137TA1902

### Single-end trolleys

REF	Dimension					Loading surface	Weight	Load cap.	Wheel diam.
	mm			mm					
	a	b	c	d	e				
137TA1902	1128	700	1006	1026	700	40,0	1000	200	
137TA1903	1328	800	1006	1226	800	46,5	1000	200	
137TA1904	1728	800	1006	1626	800	53,0	1000	200	
161TA6516	2128	800	1006	2026	800	64,0	1000	200	

Swivel castors with wheel brakes and foot guards for your safety.



Double-end trolley  
REF 137TA1905

### Double-end trolleys

REF	Dimension					Loading surface	Weight	Load cap.	Wheel diam.
	mm			mm					
	a	b	c	d	e				
137TA1905	1197	700	1006	993	700	46,5	1000	200	
137TA1906	1397	800	1006	1193	800	54,0	1000	200	
137TA1907	1797	800	1006	1593	800	61,0	1000	200	
161TA6517	2197	800	1006	1993	800	73,0	1000	200	

Swivel castors with wheel brakes and foot guards for your safety.



Three-sided trolley, side wall removable  
REF 161TA6508

### Three-sided trolleys, side wall removable

REF	Dimension					Loading surface	Weight	Load cap.	Wheel diam.
	mm			mm					
	a	b	c	d	e				
161TA6508	1197	700	1006	993	688	56,0	1000	200	
161TA6532	1397	800	1006	1193	788	67,5	1000	200	
161TA6533	1797	800	1006	1593	788	76,5	1000	200	
161TA6534	2197	800	1006	1993	788	85,5	1000	200	

Swivel castors with wheel brakes and foot guards for your safety.



Four-sided trolley, side walls removable  
REF 161TA6510

### Four-sided trolleys, side walls removable

REF	Dimension					Loading surface	Weight	Load cap.	Wheel diam.
	mm			mm					
	a	b	c	d	e				
161TA6510	1197	700	1006	993	676	62,5	1000	200	
161TA6536	1397	800	1006	1193	776	75,0	1000	200	
161TA6531	1797	800	1006	1593	776	86,5	1000	200	
161TA6537	2197	800	1006	1993	776	98,0	1000	200	

Swivel castors with wheel brakes and foot guards for your safety.





# Heavy-duty trolleys

## Heavy-duty trolleys

3 different sizes; various carrying capacities; with or without waterproof bonded plywood base, surface finish screen printed, anti-slip; Powder-coated RAL 5010 gentian blue; permanent surface protection; impact- and scratch-resistant; Grey non-marking thermoplastic rubber tyres with precision deep-groove ball bearings; thread and foot guard; 2 swivel castors with wheel brakes and 2 fixed castors; 1200 kg carrying capacity and over: elastic solid-rubber tyres on cast aluminium wheels; ball-bearing hubs; foot guard; 2 swivel castors with wheel brakes and 2 fixed castors; side and end height: 800 mm; post length: 600 mm; load surface height: 305 mm



Version TR  
REF 120TA9892

Basic model  
REF 120TA9893



### Basic model

REF		Dimension			Loading surface		Weight kg	Load cap. kg	Wheel diam. mm
		mm			mm				
		a	b	c	d	e			
120TA9888	TR	1380	880	305	1380	880	50,0	500	200
120TA9889	ER	1380	880	305	1380	880	51,0	1200	200
120TA9890	TR	1680	880	305	1680	880	53,0	500	200
120TA9891	ER	1680	880	305	1680	880	54,0	1200	200
120TA9892	TR	2080	880	305	2080	880	59,0	500	200
120TA9893	ER	2080	880	305	2080	880	60,0	1200	200



Swivel castors with wheel brakes and foot guards for your safety.

TR = Thermoplastic rubber tyres, ER = Elastic rubber tyres

### Stanchion trolleys

REF		Dimension			Loading surface		Weight kg	Load cap. kg	Wheel diam. mm
		mm			mm				
		a	b	c	d	e			
120TA9894	TR	1380	880	905	1300	800	52,0	500	200
120TA9895	ER	1380	880	905	1300	800	53,0	1200	200
120TA9896	TR	1680	880	905	1600	800	55,0	500	200
120TA9897	ER	1680	880	905	1600	800	56,0	1200	200
120TA9898	TR	2080	880	905	2000	800	61,0	500	200
120TA9899	ER	2080	880	905	2000	800	62,0	1200	200



Swivel castors with wheel brakes and foot guards for your safety.

TR = Thermoplastic rubber tyres, ER = Elastic rubber tyres

Stanchion trolley  
REF 120TA9899



### Single-end trolleys

REF		Dimension			Loading surface		Weight kg	Load cap. kg	Wheel diam. mm
		mm			mm				
		a	b	c	d	e			
120TA9900	TR	1510	880	1105	1340	880	62,0	500	200
120TA9901	ER	1510	880	1105	1340	880	63,0	1200	200
120TA9902	TR	1810	880	1105	1640	880	66,0	500	200
120TA9903	ER	1810	880	1105	1640	880	67,0	1200	200
120TA9904	TR	2210	880	1105	2040	880	74,0	500	200
120TA9905	ER	2210	880	1105	2040	880	75,0	1200	200



Swivel castors with wheel brakes and foot guards for your safety.

TR = Thermoplastic rubber tyres, ER = Elastic rubber tyres

Single-end trolley  
REF 120TA9905



### Double-end trolleys

REF		Dimension			Loading surface		Weight kg	Load cap. kg	Wheel diam. mm
		mm			mm				
		a	b	c	d	e			
120TA9906	TR	1640	880	1105	1300	880	72,0	500	200
120TA9907	ER	1640	880	1105	1300	880	73,0	1200	200
120TA9908	TR	1940	880	1105	1600	880	76,0	500	200
120TA9909	ER	1940	880	1105	1600	880	77,0	1200	200
120TA9910	TR	2340	880	1105	2000	880	84,0	500	200
120TA9911	ER	2340	880	1105	2000	880	85,0	1200	200



Swivel castors with wheel brakes and foot guards for your safety.

TR = Thermoplastic rubber tyres, ER = Elastic rubber tyres

Double-end trolley  
REF 120TA9911



### Three-sided trolleys, side wall removable

REF		Dimension			Loading surface		Weight kg	Load cap. kg	Wheel diam. mm
		mm			mm				
		a	b	c	d	e			
120TA9912	TR	1640	880	1105	1300	840	78,0	500	200
120TA9913	ER	1640	880	1105	1300	840	79,0	1200	200
120TA9914	TR	1940	880	1105	1600	840	86,0	500	200
120TA9915	ER	1940	880	1105	1600	840	87,0	1200	200
120TA9916	TR	2340	880	1105	2000	840	96,0	500	200
120TA9917	ER	2340	880	1105	2000	840	97,0	1200	200



Swivel castors with wheel brakes and foot guards for your safety.

TR = Thermoplastic rubber tyres, ER = Elastic rubber tyres

Three-sided trolley  
REF 120TA9917



### Four-sided trolleys, side walls removable

REF		Dimension			Loading surface		Weight kg	Load cap. kg	Wheel diam. mm
		mm			mm				
		a	b	c	d	e			
120TA9918	TR	1640	880	1105	1300	800	84,0	500	200
120TA9919	ER	1640	880	1105	1300	800	85,0	1200	200
120TA9920	TR	1940	880	1105	1600	800	96,0	500	200
120TA9921	ER	1940	880	1105	1600	800	97,0	1200	200
120TA9922	TR	2340	880	1105	2000	800	108,0	500	200
120TA9923	ER	2340	880	1105	2000	800	109,0	1200	200



Swivel castors with wheel brakes and foot guards for your safety.

TR = Thermoplastic rubber tyres, ER = Elastic rubber tyres

Four-sided trolley  
REF 120TA9923



# Box trolleys



## Box trolleys

Modular system; Base structure with innovative frame section; Load surface wood-based board, surface finish beech; Trolley powder-coated RAL 5010 gentian blue; permanent surface protection; impact- and scratch-resistant; Grey non-marking thermoplastic rubber tyres with precision deep-groove ball bearings; thread and foot guard; 2 swivel castors with wheel brakes and 2 fixed castors; Usable height 800 mm; All trolleys with flap-down half wall on one side



### Box trolleys with welded-in mesh 50 x 50 mm

REF	Dimension			Loading surface		Weight	Load cap.	Wheel diam.
	mm			mm				
	a	b	c	d	e	kg	kg	mm
121TA1032	1060	715	1091	1000	645	50,5	500	200
121TA1033	1260	815	1091	1200	745	57,5	500	200

Swivel castors with wheel brakes and foot guards for your safety.

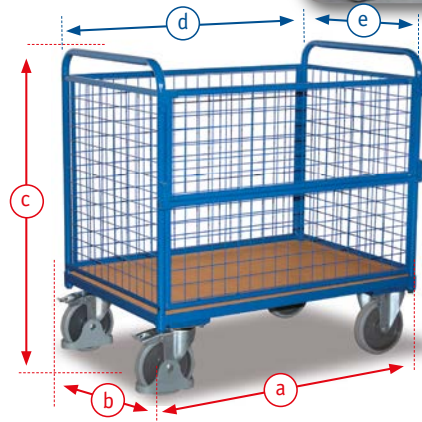

Box trolley  
REF 121TA1032

### Box trolleys with board panels

REF	Dimension			Loading surface		Weight	Load cap.	Wheel diam.
	mm			mm				
	a	b	c	d	e	kg	kg	mm
121TA1034	1060	715	1091	1000	645	68,0	500	200
121TA1035	1260	815	1091	1200	745	78,5	500	200

Swivel castors with wheel brakes and foot guards for your safety.



Box trolley  
REF 121TA1034

## Box trolleys

Angle-steel construction; welded; with tubular pushbar; Load surface and sides of wood-based board, surface finish beech; With staples for padlock; Trolley powder-coated RAL 5010 gentian blue; permanent surface protection; impact- and scratch-resistant; Grey non-marking thermoplastic rubber tyres with precision deep-groove ball bearings; thread and foot guard; 2 swivel castors with wheel brakes and 2 fixed castors



### Box trolleys with welded-in mesh 50 x 50 mm, double-flap lid - lies flat against side, lockable (facility for padlock)

REF	Dimension			Loading surface		Weight	Load cap.	Wheel diam.
	mm			mm				
	a	b	c	d	e	kg	kg	mm
121TA1036	1130	732	1109	977	677	68,5	500	200
121TA1037	1330	832	1109	1177	777	78,5	500	200

Swivel castors with wheel brakes and foot guards for your safety.



Box trolley  
REF 121TA1036



### Box trolleys with wood-based boards, double-fold lid - lies flat against side, lockable (facility for padlock)

REF	Dimension			Loading surface		Weight	Load cap.	Wheel diam.
	mm			mm				
	a	b	c	d	e	kg	kg	mm
121TA1038	1130	732	1109	970	670	88,0	500	200
121TA1039	1330	832	1109	1170	770	102,5	500	200

Swivel castors with wheel brakes and foot guards for your safety.



Box trolley  
REF 121TA1038



### Steel Box trolleys with single-flap lid - lies flat against side, with 2 gas pressure springs, lockable (facility for padlock)

REF	Dimension			Loading surface		Weight	Load cap.	Wheel diam.
	mm			mm				
	a	b	c	d	e	kg	kg	mm
120TA9811	1165	732	1069	990	690	91,5	500	200
120TA9812	1365	832	1069	1190	790	107,0	500	200

### Steel Box trolleys, open

161TA6184	1130	718	1064	990	690	71,0	500	200
161TA6185	1330	818	1064	1190	790	81,5	500	200

Swivel castors with wheel brakes and foot guards for your safety.



Box trolley, open  
REF 161TA6184

Box trolley  
REF 120TA9811



# Box trolleys / Side-frame trolleys

**VARIOfit**  
The perfect form of transport



Box trolley  
REF 161TA6456

## Box trolleys / Side-frame trolleys

Modular system; Base structure with innovative frame section; load surface wood-based board, surface finish beech; Trolley powder-coated RAL 5010 gentian blue; permanent surface protection; impact and scratch-resistant; Grey non-marking thermoplastic rubber tyres with precision deep-groove ball bearings; thread and foot guard; 2 swivel castors with wheel brakes and 2 fixed castors

### Box trolleys, side height 200 mm, mesh sides 50 x 50 mm

REF	Dimension			Loading surface		Weight kg	Load cap. kg	Wheel diam. mm
	mm			mm				
	a	b	c	d	e			
161TA6456	975	500	966	850	452	32,0	400	160
161TA6482	1125	600	1006	1000	552	37,5	500	200
161TA6509	1125	700	1006	1000	652	39,5	500	200
161TA6535	1325	800	1006	1200	752	45,5	500	200

Swivel castors with wheel brakes and foot guards for your safety.



Box trolley  
REF 120TA9799

### Box trolleys, side height 200 mm, individually removable sides

Art/REF No.	Dimension			Loading surface		Weight kg	Load cap. kg	Wheel diam. mm
	mm			mm				
	a	b	c	d	e			
120TA9799	975	500	966	850	452	32,0	400	160
161TA6178	1125	600	1006	1000	552	36,5	500	200
120TA9800	1125	700	1006	1000	652	40,0	500	200
120TA9801	1325	800	1006	1200	752	45,0	500	200

Swivel castors with wheel brakes and foot guards for your safety.



Side-frame trolley  
REF 120TA9804

### Side-frame trolleys with 2 board sides, side height 746 mm

REF	Dimension			Loading surface		Weight kg	Load cap. kg	Wheel diam. mm
	mm			mm				
	a	b	c	d	e			
120TA9804	1060	600	1036	1060	540	45,5	500	200
120TA9802	1060	700	1036	1060	640	47,0	500	200
120TA9803	1260	800	1036	1260	740	54,5	500	200

Swivel castors with wheel brakes and foot guards for your safety.



# Side-frame trolleys



**VARIOfit**  
 The perfect form  
 of transport

## Side-frame trolleys with 2 mesh side frames 50 x 50 mm, side-frame height 746 mm

REF	Dimension			Loading surface		Weight	Load cap.	Wheel diam.
	mm			mm				
	a	b	c	d	e	kg	kg	mm
161TA6471	1060	600	1036	1060	540	37,5	500	200
161TA6495	1060	700	1036	1060	640	39,0	500	200
161TA6518	1260	800	1036	1260	740	47,5	500	200

Swivel castors with wheel brakes and foot guards for your safety.



Side-frame trolley  
REF 161TA6471

## Side-frame trolleys with 2 tubular side walls, side height 746 mm

REF	Dimension			Loading surface		Weight	Load cap.	Wheel diam.
	mm			mm				
	a	b	c	d	e	kg	kg	mm
161TA6180	1060	600	1036	1060	540	37,0	500	200
120TA9805	1060	700	1036	1060	640	38,5	500	200
120TA9806	1260	800	1036	1260	740	44,0	500	200

Swivel castors with wheel brakes and foot guards for your safety.



Side-frame trolley  
REF 161TA6180

## Side-frame trolleys with 4 tubular side frames, side-frame height 746 mm

REF	Dimension			Loading surface		Weight	Load cap.	Wheel diam.
	mm			mm				
	a	b	c	d	e	kg	kg	mm
120TA9796	910	500	981	910	440	29,5	400	160
161TA6179	1060	600	1021	1060	540	34,0	500	200
120TA9797	1060	700	1021	1060	640	35,0	500	200
120TA9798	1260	800	1021	1260	740	41,0	500	200

Swivel castors with wheel brakes and foot guards for your safety.



Side-frame trolley  
REF 120TA9796





# ESD trolleys

(electrostatic discharge)

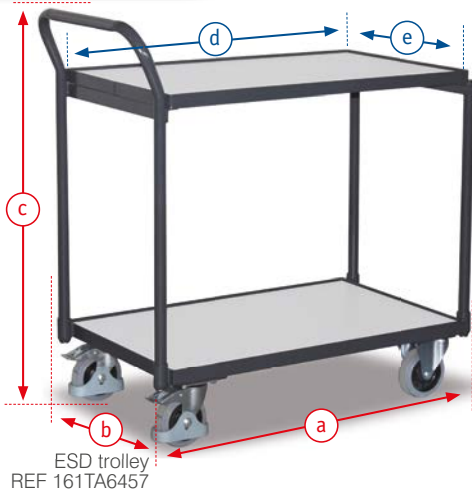

## ESD trolleys

Modular system; Base structure of innovative frame section; load surfaces of electrically conductive faced chipboard light grey; Trolley powder-coated RAL 7024 graphite grey; electrically conductive; permanent surface protection; impact- and scratch-resistant; Electrically conductive thermoplastic rubber tyres on plastic wheels with ball bearings; thread and foot guard; 2 swivel castors with wheel brakes and 2 fixed castors

### ESD table trolleys with 2 load surfaces, edge 12 mm high

REF	Dimension			Loading surface		Weight	Load cap.	Wheel diam.
	a	b	c	d	e			
161TA6457	975	524	980	850	500	34,5	250	125
161TA6483	1125	624	980	1000	600	42,5	250	125

Swivel castors with wheel brakes and foot guards for your safety.



ESD trolley  
REF 161TA6458

### ESD table trolleys with 3 load surfaces, edge 12 mm high

REF	Dimension			Loading surface		Weight	Load cap.	Wheel diam.
	a	b	c	d	e			
161TA6458	975	524	980	850	500	46,0	250	125
161TA6485	1125	624	980	1000	600	57,5	250	125

Swivel castors with wheel brakes and foot guards for your safety.



ESD trolley  
REF 161TA6668

### ESD Heavy-duty table trolleys with 2 load surfaces

REF	Dimension			Loading surface		Weight	Load cap.	Wheel diam.
	a	b	c	d	e			
161TA6668	1040	500	875	850	500	41,0	400	160
161TA6675	1140	600	915	1000	600	51,0	500	200
161TA6684	1140	700	915	1000	700	62,0	500	200
161TA6690	1340	800	915	1200	800	69,0	500	200

Swivel castors with wheel brakes and foot guards for your safety.



ESD trolley  
REF 161TA6669

### ESD Heavy-duty table trolleys with 3 load surfaces

REF	Dimension			Loading surface		Weight	Load cap.	Wheel diam.
	a	b	c	d	e			
161TA6669	1040	500	875	850	500	55,0	400	160
161TA6676	1140	600	915	1000	600	69,0	500	200
161TA6686	1140	700	915	1000	700	72,0	500	200
161TA6692	1340	800	915	1200	800	86,0	500	200

Swivel castors with wheel brakes and foot guards for your safety.



optional



**Note:** These trolleys are suitable for use in situations where there is a need to prevent static charging of the payload or the materials handling equipment, e.g. plastics, electronic devices etc.

**ESD shelf trolleys with 3 shelves**

REF	Dimension			Loading surface		Weight	Load cap.	Wheel diam.
	mm			mm				
	a	b	c	d	e			
161TA6446	910	500	986	850	500	50,0	250	160
161TA6472	1060	600	986	1000	600	55,5	250	160
161TA6505	1060	700	986	1000	700	61,5	250	160
161TA6528	1260	800	986	1200	800	76,0	250	160

Swivel castors with wheel brakes and foot guards for your safety.



ESD trolley  
REF 161TA6446

**ESD shelf trolleys, high, with 3 shelves**

REF	Dimension			Loading surface		Weight	Load cap.	Wheel diam.
	mm			mm				
	a	b	c	d	e			
161TA6447	910	500	1524	850	500	50,5	250	160
161TA6473	1060	600	1524	1000	600	60,5	250	160
161TA6506	1060	700	1524	1000	700	67,0	250	160
161TA6529	1260	800	1524	1200	800	81,5	250	160

Swivel castors with wheel brakes and foot guards for your safety.



ESD trolley  
REF 161TA6447

**Additional Articles for ESD - shelf trolleys**

REF	Dimension	for Loading surface	Weight	Load cap.	
	mm	mm			
161TA6603	878 x 485	850 x 500	7,0	80	Extra shelf
161TA6607	1028 x 585	1000 x 600	9,0	80	Extra shelf
161TA6612	1028 x 685	1000 x 700	11,5	80	Extra shelf
161TA6615	1228 x 785	1200 x 800	15,0	80	Extra shelf

**ESD shelf trolleys, high, with 5 shelves**

REF	Dimension			Loading surface		Weight	Load cap.	Wheel diam.
	mm			mm				
	a	b	c	d	e			
161TA6448	910	500	1524	850	500	64,0	250	160
161TA6474	1060	600	1524	1000	600	79,5	250	160
161TA6507	1060	700	1524	1000	700	89,5	250	160
161TA6530	1260	800	1524	1200	800	112,0	250	160

Swivel castors with wheel brakes and foot guards for your safety.



ESD trolley  
REF 161TA6448

**ESD - Euro system dolly with 2 load surfaces and 10 mm edge**

REF	Dimension			Loading surface		Weight	Load cap.	Wheel diam.
	mm			mm				
	a	b	c	d	e			
161TA6798	680	420	654	610	410	19,0	250	125

**ESD - Euro system dolly with 2 load surfaces and plate flush with frame**

161TA6799	680	420	654	610	410	20,0	250	125
-----------	-----	-----	-----	-----	-----	------	-----	-----

Swivel castors with wheel brakes and foot guards for your safety.



ESD - Euro system dolly  
REF 161TA6799  
ESD - Euro system dolly  
REF 161TA6798

**ESD - Push-handle dolly with 2 board load surfaces, heights 185 / 770 mm**

REF	Dimension			Loading surface		Weight	Load cap.	Wheel diam.
	mm			mm				
	a	b	c	d	e			
161TA6802	891	450	883	603	450	16,0	250	125

Swivel castors with wheel brakes and foot guards for your safety.



ESD - Push-handle dolly  
REF 161TA6802



# Light table trolleys

## Light table trolleys

Modular system; Base structure with innovative frame section; Load surfaces of wood-based board, surface finish beech; set in angle-steel frame, edge = 12 mm high; Trolley powder-coated RAL 5010 gentian blue; permanent surface protection; impact- and scratch-resistant; Grey non-marking thermoplastic rubber tyres with precision deep-groove ball bearings; thread and foot guard; 2 swivel castors with wheel brakes and 2 fixed castors



Table trolley  
REF 137TA1887



Table trolley  
REF 138TA8170



Table trolley  
REF 138TA8172



Table trolley  
REF 137TA1892

Also available as ESD version on page 26



Table trolley  
REF 137TA1893

Also available as ESD version on page 26



Table trolley  
REF 137TA1895

### Table trolleys with 2 load surfaces

REF	Dimension			Loading surface		Weight	Load cap.	Wheel diam.
	a	b	c	d	e			
137TA1887	1023	524	850	850	500	28,0	250	125
137TA1888	1173	624	850	1000	600	33,5	250	125

Swivel castors with wheel brakes and foot guards for your safety.

### Table trolleys with 3 load surfaces

REF	Dimension			Loading surface		Weight	Load cap.	Wheel diam.
	a	b	c	d	e			
138TA8170	1023	524	850	850	500	37,0	250	125
138TA8171	1173	624	850	1000	600	45,0	250	125

Swivel castors with wheel brakes and foot guards for your safety.



Table trolleys with 2 load surfaces and 2 lockable drawers, drawer divider set available as accessory  
Drawer divider set - additional Articles on page 9 (zsw-600.604)

REF	Dimension			Loading surface		Weight	Load cap.	Wheel diam.
	a	b	c	d	e			
138TA8172	1173	624	850	1000	600	45,0	250	125

Swivel castors with wheel brakes and foot guards for your safety.

### Table trolleys with 2 load surfaces

REF	Dimension			Loading surface		Weight	Load cap.	Wheel diam.
	a	b	c	d	e			
137TA1892	975	524	1010	850	500	28,0	250	125
136TA8402	1125	624	1010	1000	600	34,0	250	125

Swivel castors with wheel brakes and foot guards for your safety.

### Table trolleys with 3 load surfaces

REF	Dimension			Loading surface		Weight	Load cap.	Wheel diam.
	a	b	c	d	e			
137TA1893	975	524	1010	850	500	37,5	250	125
137TA1894	1125	624	1010	1000	600	45,0	250	125

Swivel castors with wheel brakes and foot guards for your safety.



Table trolleys with 2 load surfaces and 2 lockable drawers, drawer divider set available as accessory  
Drawer divider set - additional Articles on page 9 (zsw-600.604)

REF	Dimension			Loading surface		Weight	Load cap.	Wheel diam.
	a	b	c	d	e			
137TA1895	1125	624	1010	1000	600	45,0	250	125

Swivel castors with wheel brakes and foot guards for your safety.



# Heavy-duty table trolleys



optional



MODULAR SYSTEM



## Heavy-duty table trolleys

Modular system; Base structure with innovative frame section and wood-based board, surface finish beech, or waterproof bonded plywood, surface finish screen printed, anti-slip; Trolley powder-coated RAL 5010 gentian blue; permanent surface protection; impact- and scratch-resistant; Grey non-marking thermoplastic rubber tyres with precision deep-groove ball bearings or elastic solid-rubber tyres on cast aluminium wheels with ball bearings; thread and foot guard; 2 swivel castors with wheel brakes and 2 fixed castors



### Heavy-duty table trolleys with 2 wood-based load surfaces covered with galvanised sheet

REF	Dimension			Loading surface		Weight	Load cap.	Wheel diam.
	mm	mm	mm	mm	mm			
	a	b	c	d	e	kg	kg	mm
120TA9873	1190	700	921	1000	700	52,0	500	200
120TA9874	1390	800	921	1200	800	63,5	500	200

Swivel castors with wheel brakes and foot guards for your safety.

### Heavy-duty table trolleys with 2 load surfaces

REF	Dimension			Loading surface		Weight	Load cap.	Wheel diam.
	mm	mm	mm	mm	mm			
	a	b	c	d	e	kg	kg	mm
137TA1896	1040	500	905	850	500	37,0	400	160
120TA9875	1190	600	921	1000	600	42,0	500	200
120TA9876	1190	700	921	1000	700	47,0	500	200
120TA9877	1390	800	921	1200	800	52,5	500	200

Swivel castors with wheel brakes and foot guards for your safety.

### Heavy-duty table trolleys with 2 load surfaces of waterproof bonded plywood, surface finish screen printed

REF	Dimension			Loading surface		Weight	Load cap.	Wheel diam.
	mm	mm	mm	mm	mm			
	a	b	c	d	e	kg	kg	mm
137TA1908	1190	700	921	993	700	59,5	1000	200
137TA1909	1390	800	921	1193	800	77,0	1000	200
137TA1910	1790	800	921	1593	800	87,0	1000	200
161TA6538	2190	800	921	1993	800	103,5	1000	200

Swivel castors with wheel brakes and foot guards for your safety.

### Heavy-duty table trolleys with 3 load surfaces

REF	Dimension			Loading surface		Weight	Load cap.	Wheel diam.
	mm	mm	mm	mm	mm			
	a	b	c	d	e	kg	kg	mm
137TA1897	1040	500	905	850	500	43,5	400	160
137TA1898	1190	600	921	1000	600	53,5	500	200
120TA9878	1190	700	921	1000	700	59,0	500	200
120TA9879	1390	800	921	1200	800	69,5	500	200

Swivel castors with wheel brakes and foot guards for your safety.

### Heavy-duty table trolleys with 3 load surfaces of waterproof bonded plywood, surface finish screen printed

REF	Dimension			Loading surface		Weight	Load cap.	Wheel diam.
	mm	mm	mm	mm	mm			
	a	b	c	d	e	kg	kg	mm
161TA6511	1190	700	921	993	700	66,0	1000	200
161TA6539	1390	800	921	1193	800	98,5	1000	200
161TA6540	1790	800	921	1593	800	118,0	1000	200
161TA6541	2190	800	921	1993	800	137,0	1000	200

Swivel castors with wheel brakes and foot guards for your safety.

### Heavy-duty table trolleys with 4 load surfaces

REF	Dimension			Loading surface		Weight	Load cap.	Wheel diam.
	mm	mm	mm	mm	mm			
	a	b	c	d	e	kg	kg	mm
120TA9880	1190	700	1260	1000	700	74,5	500	200
120TA9881	1390	800	1260	1200	800	88,0	500	200

Swivel castors with wheel brakes and foot guards for your safety.

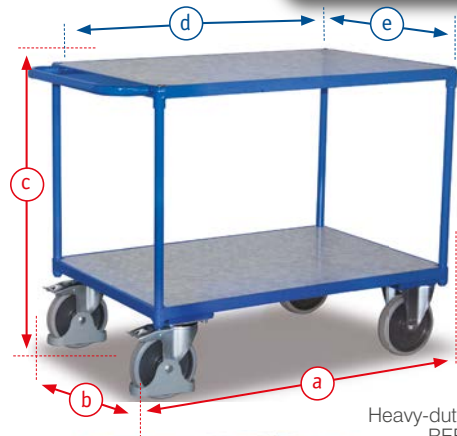

Heavy-duty table trolley REF 120TA9873



Heavy-duty table trolley REF 137TA1896



Heavy-duty table trolley REF 137TA1908



Heavy-duty table trolley REF 137TA1897



Heavy-duty table trolley REF 161TA6511



Heavy-duty table trolley REF 120TA9880

Also available as ESD version on page 26

Also available as ESD version on page 26



# Table trolleys



Table trolley with pushbar  
REF 138TA3973

## Table trolleys

Modular system; Load surfaces of wood-based board, surface finish beech; Trolley powder-coated RAL 5010 gentian blue; permanent surface protection; impact- and scratch-resistant; Grey non-marking thermoplastic rubber tyres with precision deep-groove ball bearings; thread and foot guard; 2 swivel castors with wheel brakes and 2 fixed castors



### Table trolleys with pushbar

REF	Dimension			Loading surface		Weight kg	Load cap. kg	Wheel diam. mm
	mm			mm				
	a	b	c	d	e			
138TA3973	955	505	967	850	500	31,5	400	160
138TA3974	1105	705	1007	1000	700	39,5	400	200
138TA3975	1305	705	1007	1200	700	46,0	400	200

Swivel castors with wheel brakes and foot guards for your safety.



Table trolley  
REF 138TA3976



### Table trolleys with 2 load surfaces, removable upper shelf (capacity 80 kg)

REF	Dimension			Loading surface		Weight kg	Load cap. kg	Wheel diam. mm
	mm			mm				
	a	b	c	d	e			
138TA3976	1040	500	927	850	500	28,5	200	125
138TA3977	1190	600	927	1000	600	34,5	200	125

Swivel castors with wheel brakes and foot guards for your safety.



Steel table trolley  
REF 163TA7884

## Table trolleys

Welded steel or aluminium construction; Load surfaces of wood-based board, surface finish beech; edge 20 mm high; Steel table trolley powder-coated RAL 5010 gentian blue; permanent surface protection; impact- and scratch-resistant; Grey non-marking thermoplastic rubber tyres with precision deep-groove ball bearings; thread and foot guard; 2 swivel castors with wheel brakes and 2 fixed castors

### Steel table trolleys

REF	Dimension			Loading surface		Weight kg	Load cap. kg	Wheel diam. mm
	mm			mm				
	a	b	c	d	e			
163TA7884	1090	600	970	970	570	33,0	200	125

Swivel castors with wheel brakes and foot guards for your safety.



Aluminium table trolley  
REF 138TA3978

### Aluminium table trolleys

REF	Dimension			Loading surface		Weight kg	Load cap. kg	Wheel diam. mm
	mm			mm				
	a	b	c	d	e			
138TA3978	1085	600	970	970	570	24,5	200	125

Swivel castors with wheel brakes and foot guards for your safety.

# Parcel trolleys



**VARIOfit**  
 The perfect form  
 of transport

## Parcel trolleys

Modular system; Base structure with innovative frame section and wood-based board, surface finish beech; Optional removable shelves for insertion at 120 mm intervals; Mesh sides and ends, mesh size 120 x 120 mm; Trolley powder-coated RAL 5010 gentian blue; permanent surface protection; impact- and scratch-resistant; Grey non-marking thermoplastic rubber tyres with precision deep-groove ball bearings; thread and foot guard; 2 swivel castors with wheel brakes and 2 fixed castors

### Three-sided parcel trolleys, high

REF	Dimension			Loading surface		Weight	Load cap.	Wheel diam.
	a	b	c	d	e			
161TA6451	1039	527	1776	850	500	43,5	400	160
161TA6477	1189	627	1816	1000	600	51,5	500	200
120TA9845	1189	727	1816	1000	700	59,5	500	200
120TA9846	1389	827	1816	1200	800	67,5	500	200

Swivel castors with wheel brakes and foot guards for your safety.



Three-sided parcel trolley  
REF 161TA6451

### Three-sided parcel trolleys, low

REF	Dimension			Loading surface		Weight	Load cap.	Wheel diam.
	a	b	c	d	e			
161TA6453	1039	527	1176	850	500	36,5	400	160
161TA6479	1189	627	1216	1000	600	43,0	500	200
137TA1883	1189	727	1216	1000	700	50,0	500	200
137TA1884	1389	827	1216	1200	800	57,0	500	200

Swivel castors with wheel brakes and foot guards for your safety.



Three-sided parcel trolley  
REF 161TA6453

### Additional articles for parcel trolleys and shelf trolleys

REF	Dimension	for Loading surface	Weight	Load cap.	
	mm				
161TA6602	890 x 480	850 x 500	7,5	80	Extra shelf incl. angle support
161TA6606	1040 x 580	1000 x 600	11,5	80	Extra shelf incl. angle support
161TA6189	1040 x 680	1000 x 700	11,5	80	Extra shelf incl. angle support
161TA6190	1240 x 780	1200 x 800	15,5	80	Extra shelf incl. angle support
161TA6408	1525 x 820	850 x 500	7,5	-	Extra side, high
161TA6191	1525 x 970	1000 x 700	8,0	-	Extra side, high
161TA6192	1525 x 1170	1200 x 800	9,5	-	Extra side, high

### Four-sided parcel trolleys, high

REF	Dimension			Loading surface		Weight	Load cap.	Wheel diam.
	a	b	c	d	e			
161TA6454	1039	547	1776	850	500	48,5	400	160
161TA6480	1189	647	1816	1000	600	57,5	500	200
120TA9847	1189	747	1816	1000	700	67,0	500	200
120TA9848	1389	847	1816	1200	800	76,5	500	200

Swivel castors with wheel brakes and foot guards for your safety.



Four-sided parcel trolley  
REF 161TA6454

### Four-sided parcel trolleys, low

REF	Dimension			Loading surface		Weight	Load cap.	Wheel diam.
	a	b	c	d	e			
161TA6455	1039	547	1176	850	500	40,0	400	160
161TA6481	1189	647	1216	1000	600	47,5	500	200
137TA1885	1189	747	1216	1000	700	55,0	500	200
137TA1886	1389	847	1216	1200	800	62,5	500	200

Swivel castors with wheel brakes and foot guards for your safety.



Four-sided parcel trolley  
REF 161TA6455



# Shelf trolleys



optional

## Shelf trolleys

Base structure with innovative frame section; Load surface and shelves of wood-based board, surface finish beech; capacity per shelf 80 kg; Mesh sides and ends, mesh size 120 x 120 mm; Trolley powder-coated RAL 5010 gentian blue; permanent surface protection; impact- and scratch-resistant; Grey non-marking thermoplastic rubber tyres with precision deep-groove ball bearings; thread and foot guard; 2 swivel castors with wheel brakes and 2 fixed castors



Shelf trolley  
REF 161TA6444



MODULAR SYSTEM



### Shelf trolleys with 2 ends and 3 shelves

REF	Dimension			Loading surface		Weight	Load cap.	Wheel diam.
	mm			mm				
	a	b	c	d	e	kg	kg	mm
161TA6444	1033	517	1176	850	500	53,5	400	160
161TA6469	1183	617	1216	1000	600	65,0	500	200
120TA9833	1183	717	1216	1000	700	68,5	500	200
120TA9834	1383	817	1216	1200	800	81,5	500	200

Swivel castors with wheel brakes and foot guards for your safety.

For additional sides and shelves, see page 31 and 32



Shelf trolley  
REF 138TA8168



MODULAR SYSTEM



### Shelf trolleys, high, with 2 ends and 4 shelves

REF	Dimension			Loading surface		Weight	Load cap.	Wheel diam.
	mm			mm				
	a	b	c	d	e	kg	kg	mm
138TA8168	1033	517	1776	850	500	67,5	400	160
138TA8169	1183	617	1816	1000	600	81,0	500	200
120TA9837	1183	717	1816	1000	700	86,0	500	200
120TA9838	1383	817	1816	1200	800	104,0	500	200

Swivel castors with wheel brakes and foot guards for your safety.



Additional backwall with  
folding top half  
REF 161TA6775

### Additional articles for shelf trolleys

REF	Dimension	for Loading surface	Weight	
161TA6407	925 x 820	850 x 500	5,5	Additional backwall low
161TA6187	925 x 970	1000 x 600	6,5	Additional backwall low
161TA6187	925 x 970	1000 x 700	6,5	Additional backwall low
161TA6188	925 x 1170	1200 x 800	8,5	Additional backwall low

### Additional backwall with folding top half

161TA6773	1525 x 820	850 x 500	11,5	Additional backwall with folding top half
161TA6774	1525 x 970	1000 x 600	12,5	Additional backwall with folding top half
161TA6775	1525 x 970	1000 x 700	12,5	Additional backwall with folding top half
161TA6776	1525 x 1170	1200 x 800	13,5	Additional backwall with folding top half



Shelf trolley  
REF 161TA6445



MODULAR SYSTEM



### Shelf trolleys, high, with 2 ends and 5 shelves

REF	Dimension			Loading surface		Weight	Load cap.	Wheel diam.
	mm			mm				
	a	b	c	d	e	kg	kg	mm
161TA6445	1033	517	1776	850	500	73,0	400	160
161TA6470	1183	617	1816	1000	600	91,0	500	200
120TA9839	1183	717	1816	1000	700	97,5	500	200
120TA9840	1383	817	1816	1200	800	119,0	500	200

Swivel castors with wheel brakes and foot guards for your safety.





### Shelf trolleys with 4 ends and 3 shelves

REF	Dimension			Loading surface		Weight	Load cap.	Wheel diam.
	mm			mm				
	a	b	c	d	e			
161TA6666	1039	527	1176	850	500	64,5	400	160
161TA6674	1189	627	1216	1000	600	77,5	500	200
161TA6682	1189	727	1216	1000	700	79,5	500	200
161TA6689	1389	827	1216	1200	800	95,5	500	200

Swivel castors with wheel brakes and foot guards for your safety.



Shelf trolley  
REF 161TA6666

### Shelf trolleys, high, with 4 ends and 4 shelves

REF	Dimension			Loading surface		Weight	Load cap.	Wheel diam.
	mm			mm				
	a	b	c	d	e			
161TA6665	1039	527	1776	850	500	82,5	400	160
161TA6673	1189	627	1816	1000	600	98,0	500	200
161TA6681	1189	727	1816	1000	700	102,0	500	200
161TA6688	1389	827	1816	1200	800	122,5	500	200

Swivel castors with wheel brakes and foot guards for your safety.



Shelf trolley  
REF 161TA6665

### Shelf trolleys with 3 ends and 3 shelves

REF	Dimension			Loading surface		Weight	Load cap.	Wheel diam.
	mm			mm				
	a	b	c	d	e			
161TA6452	1039	527	1176	850	500	59,0	400	160
161TA6478	1189	627	1216	1000	600	71,0	500	200
120TA9835	1189	727	1216	1000	700	73,0	500	200
120TA9836	1389	827	1216	1200	800	87,0	500	200

Swivel castors with wheel brakes and foot guards for your safety.



Shelf trolley  
REF 161TA6452

### Shelf trolleys, high, with 3 ends and 4 shelves

REF	Dimension			Loading surface		Weight	Load cap.	Wheel diam.
	mm			mm				
	a	b	c	d	e			
161TA6449	1039	527	1776	850	500	75,0	400	160
161TA6475	1189	627	1816	1000	600	89,0	500	200
120TA9841	1189	727	1816	1000	700	94,0	500	200
120TA9842	1389	827	1816	1200	800	113,0	500	200

Swivel castors with wheel brakes and foot guards for your safety.



Shelf trolley  
REF 161TA6449

### Shelf trolleys, high, with 3 ends and 5 shelves

REF	Dimension			Loading surface		Weight	Load cap.	Wheel diam.
	mm			mm				
	a	b	c	d	e			
161TA6450	1039	527	1776	850	500	82,5	400	160
161TA6476	1189	627	1816	1000	600	101,0	500	200
120TA9843	1189	727	1816	1000	700	105,5	500	200
120TA9844	1389	827	1816	1200	800	128,0	500	200

Swivel castors with wheel brakes and foot guards for your safety.



Shelf trolley  
REF 161TA6450



# Shelf trolleys

## Shelf trolleys

Base structure with innovative frame section; Load surface and shelves of wood-based board, surface finish beech; capacity per shelf 80 kg; Mesh sides and ends, mesh size 120 x 120 mm; Trolley powder-coated RAL 5010 gentian blue; permanent surface protection; impact- and scratch-resistant; Grey non-marking thermoplastic rubber tyres with precision deep-groove ball bearings; thread and foot guard; 2 swivel castors with wheel brakes and 2 fixed castors



Shelf trolley  
REF 161TA6818



### Shelf trolleys, high, with 3 folding shelves and three sides with mesh

REF	Dimension			Loading surface		Weight	Load cap.	Wheel diam.
	mm			mm				
	a	b	c	d	e			
161TA6811	1200	700	1880	1000	700	75	500	200
161TA6818	1400	800	1880	1200	800	85	500	200

Swivel castors with wheel brakes and foot guards for your safety.



Shelf trolley  
REF 161TA6817



### Shelf trolleys, high, with 3 folding shelves

REF	Dimension			Loading surface		Weight	Load cap.	Wheel diam.
	mm			mm				
	a	b	c	d	e			
161TA6810	1200	700	1880	1000	700	68	500	200
161TA6817	1400	800	1880	1200	800	78,5	500	200

Swivel castors with wheel brakes and foot guards for your safety.

## Shelf trolleys with dead man's brake

Modular system; Base structure with innovative frame section; tubular pushbar with dead man's control, Load surface and shelves of wood-based board, surface finish beech; Shelves for variable insertion at 120 mm intervals; capacity per shelf 80 kg; Mesh sides and ends, mesh size 120 x 120 mm; Trolley powder-coated RAL 5010 gentian blue; permanent surface protection; impact- and scratch-resistant; Grey non-marking thermoplastic rubber tyres with precision deep-groove ball bearings; thread guard and foot guard; 2 swivel castors with dead man's brake and 2 fixed castors



### Shelf trolleys high with dead man's brake

REF	Dimension			Loading surface		Weight	Load cap.	Wheel diam.
	mm			mm				
	a	b	c	d	e			
161TA6812	1183	717	1816	1000	700	86,0	500	200

Swivel castors with dead man's brake and foot guards for your safety



### Shelf trolleys low with dead man's brake

REF	Dimension			Loading surface		Weight	Load cap.	Wheel diam.
	mm			mm				
	a	b	c	d	e			
161TA6807	1060	600	1524	1000	600	55,0	250	160

Swivel castors with dead man's brake and foot guards for your safety

Brake applied  
Brake released

**NEW**

Shelf trolley  
REF 161TA6812



**NEW**

Shelf trolley  
REF 161TA6807



**Table and pushbar trolleys with dead man's brake**

Modular system; shelf construction with innovative L-profile; tubular pushbar with dead man's brake load surfaces made from wood-based panels with beech surface finish; shelf frames of angled steel; load surfaces with 12-mm high edges; trolley powder-coated, RAL 5010 gentian blue; durable surface protection; impact and scratch resistant; grey non-marking thermoplastic rubber tyres, with precision deep-groove ball bearings; thread guard and foot guard; 2 swivel castors with dead man's brake and 2 fixed castors



**Table trolley with 2 load surfaces and dead man's brake**

REF	Dimension			Loading surface		Weight	Load cap.	Wheel diam.
	a	b	c	d	e			
161TA6808	1125	624	980	1000	600	34,0	250	125

Swivel castors with dead man's brake and foot guards for your safety



Shelf trolley  
REF 161TA6808

**Pushbar trolley with dead man's brake**

REF	Dimension			Loading surface		Weight	Load cap.	Wheel diam.
	a	b	c	d	e			
161TA6806	800	600	848	780	580	22,0	250	125

Swivel castors with dead man's brake and foot guards for your safety



Pushbar trolley  
REF 161TA6806

**Folding pushbar trolley with dead man's brake**

REF	Dimension			Loading surface		Weight	Load cap.	Wheel diam.
	a	b	c	d	e			
161TA6801	815	450	940	720	450	16,0	150	125

Swivel castors with dead man's brake and foot guards for your safety



Folding pushbar trolley  
REF 161TA6801





# Shelf trolleys

## Shelf trolleys with EasySTOP

Angle-steel construction; Fully welded with mesh sides 50 x 50 mm; Base and shelves of wood-based board, surface finish beech; Shelf supports for variable insertion at 100 mm intervals; Tubular pushbar; Trolley powder coated RAL 5010 gentian blue; permanent surface protection; impact- and scratch-resistant; Grey non-marking thermoplastic rubber tyres with precision deep-groove ball bearings; thread and foot guard; 2 **EasySTOP** swivel castors and 2 fixed castors; Trolleys with double doors have espagnolette bolt lock with T-handle or lever



Shelf trolley  
REF 137TA1875

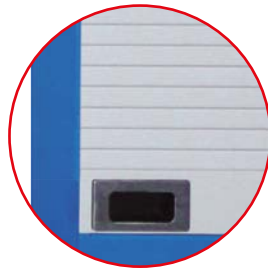

Roller shutter door on request

### Shelf trolleys with 1 fixed and 4 variable shelves

REF	Dimension			Loading surface		Weight	Load cap.	Wheel diam.
	a	b	c	d	e			
137TA1875	1115	730	1800	1040	670	114,0	500	200
137TA1876	1315	830	1800	1240	770	139,0	500	200

EasySTOP swivel castors and foot guards for your safety.



Shelf trolley  
REF 161TA6815

### Shelf trolleys with 1 fixed shelf, hinged double door with lever handle

REF	Dimension			Loading surface		Weight	Load cap.	Wheel diam.
	a	b	c	d	e			
161TA6815	1115	810	1800	1040	670	87,0	500	200
161TA6365	1315	910	1800	1240	770	99,5	500	200

EasySTOP swivel castors and foot guards for your safety.



Shelf trolley  
REF 137TA1877

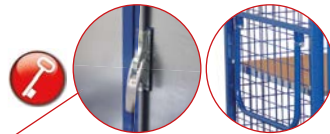

The push/pull bar is flush with the frame when not in use.

### Shelf trolleys with 1 fixed and 4 variable shelves, double door with lever handle

REF	Dimension			Loading surface		Weight	Load cap.	Wheel diam.
	a	b	c	d	e			
137TA1877	1115	810	1800	1040	670	137,0	500	200
137TA1878	1315	910	1800	1240	770	165,5	500	200

EasySTOP swivel castors and foot guards for your safety.



Shelf trolley  
REF 147TA3488

### Shelf trolleys with 1 fixed and 4 variable shelves, double door with T-handle

REF	Dimension			Loading surface		Weight	Load cap.	Wheel diam.
	a	b	c	d	e			
147TA3488	1115	730	1800	1040	670	137,0	500	200
147TA3489	1315	830	1800	1240	770	165,5	500	200

EasySTOP swivel castors and foot guards for your safety.



### Shelf trolleys with EasySTOP

Galvanised steel sheet; Fully welded; Base and shelves of wood-based board, surface finish beech; Shelf supports for variable insertion at 100 mm intervals; Tubular pushbar; Steel parts powder-coated RAL 5010 gentian blue; permanent surface protection; impact- and scratch-resistant; Grey non-marking thermoplastic rubber tyres with precision deep-groove ball bearings; thread and foot guard; 2 **EasySTOP** swivel castors and 2 fixed castors; Trolleys with double doors have espagnolette bolt lock with lever or T-handle

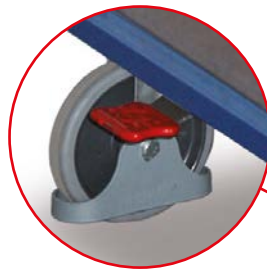

#### Shelf trolleys with 1 fixed and 4 variable shelves

REF	Dimension			Loading surface		Weight	Load cap.	Wheel diam.
	a	b	c	d	e			
137TA1879	1115	730	1800	1040	670	130,5	500	200
137TA1880	1315	830	1800	1240	770	159,0	500	200

EasySTOP swivel castors and foot guards for your safety.

Shelf trolley  
REF 137TA1879

The wing door opens 270° and is flush with the frame.



Shelf trolley  
REF 137TA1881

#### Shelf trolleys with 1 fixed and 4 variable shelves, double door with lever handle

REF	Dimension			Loading surface		Weight	Load cap.	Wheel diam.
	a	b	c	d	e			
137TA1881	1115	810	1800	1040	670	157,0	500	200
137TA1882	1315	910	1800	1240	770	191,0	500	200

EasySTOP swivel castors and foot guards for your safety.



Shelf trolley  
REF 161TA6513

#### Shelf trolleys with 1 fixed and 4 variable shelves, double door with T-handle

REF	Dimension			Loading surface		Weight	Load cap.	Wheel diam.
	a	b	c	d	e			
161TA6513	1115	730	1800	1040	670	157,0	500	200
161TA6542	1315	830	1800	1240	770	191,0	500	200

EasySTOP swivel castors and foot guards for your safety.



# Shelf trolleys, low

## Shelf trolleys, low

Modular system; Base structure with innovative frame section; Base, shelves and trays of wood-based board, surface finish beech; Tray height for all models 60 mm; Trolley powder-coated RAL 5010 gentian blue; permanent surface protection; impact- and scratchresistant; Grey non-marking thermoplastic rubber tyres with precision deep-groove ball bearings; thread and foot guard; 2 swivel castors with wheel brakes and 2 fixed castors



Shelf trolley  
REF 120TA9813

### Shelf trolleys with 2 shelves

REF	Dimension			Loading surface		Weight	Load cap.	Wheel diam.
	mm			mm				
	a	b	c	d	e	kg	kg	mm
120TA9813	910	500	986	850	500	33,5	250	160
120TA9814	1060	600	986	1000	600	40,0	250	160
161TA6496	1060	700	986	1000	700	45,5	250	160
161TA6519	1260	800	986	1200	800	54,0	250	160

Swivel castors with wheel brakes and foot guards for your safety.

Also available as ESD version on page 27



Shelf trolley  
REF 120TA9815

### Shelf trolleys with 3 shelves

REF	Dimension			Loading surface		Weight	Load cap.	Wheel diam.
	mm			mm				
	a	b	c	d	e	kg	kg	mm
120TA9815	910	500	986	850	500	39,5	250	160
120TA9816	1060	600	986	1000	600	48,0	250	160
161TA6497	1060	700	986	1000	700	56,0	250	160
161TA6520	1260	800	986	1200	800	68,5	250	160

Swivel castors with wheel brakes and foot guards for your safety.



Shelf trolley  
REF 120TA9817

### Shelf trolleys with 2 shelves and 1 tray

REF	Dimension			Loading surface		Weight	Load cap.	Wheel diam.
	mm			mm				
	a	b	c	d	e	kg	kg	mm
120TA9817	910	500	986	815	455	40,0	250	160
120TA9818	1060	600	986	965	555	48,5	250	160
161TA6498	1060	700	986	965	655	57,0	250	160
161TA6521	1260	800	986	1165	755	69,0	250	160

Swivel castors with wheel brakes and foot guards for your safety.



Shelf trolley  
REF 120TA9819

### Shelf trolleys with 1 shelf and 1 tray

REF	Dimension			Loading surface		Weight	Load cap.	Wheel diam.
	mm			mm				
	a	b	c	d	e	kg	kg	mm
120TA9819	910	500	986	815	455	34,0	250	160
120TA9820	1060	600	986	965	555	40,5	250	160
161TA6499	1060	700	986	965	655	46,5	250	160
161TA6522	1260	800	986	1165	755	55,0	250	160

Swivel castors with wheel brakes and foot guards for your safety.



Shelf trolley  
REF 120TA9821

### Shelf trolley with 2 trays

REF	Dimension			Loading surface		Weight	Load cap.	Wheel diam.
	mm			mm				
	a	b	c	d	e	kg	kg	mm
120TA9821	910	500	986	815	455	37,0	250	160
120TA9822	1060	600	986	965	555	43,5	250	160
161TA6500	1060	700	986	965	655	50,5	250	160
161TA6523	1260	800	986	1165	755	60,0	250	160

Swivel castors with wheel brakes and foot guards for your safety.



Shelf trolley  
REF 120TA9823

### Shelf trolleys with 3 trays

REF	Dimension			Loading surface		Weight	Load cap.	Wheel diam.
	mm			mm				
	a	b	c	d	e	kg	kg	mm
120TA9823	910	500	986	815	455	43,0	250	160
120TA9824	1060	600	986	965	555	52,5	250	160
161TA6501	1060	700	986	965	655	61,5	250	160
161TA6524	1260	800	986	1165	755	73,5	250	160

Swivel castors with wheel brakes and foot guards for your safety.



# Shelf trolleys, high



## Shelf trolleys, high

Modular system; Base structure with innovative frame section; Base, shelves and trays of wood-based board, surface finish beech; Tray height for all models 60 mm; Trolley powder-coated RAL 5010 gentian blue; permanent surface protection; impact- and scratch-resistant; Grey non-marking thermoplastic rubber tyres with precision deep-groove ball bearings; thread and foot guard; 2 swivel castors with wheel brakes and 2 fixed castors

### Shelf trolleys with 3 shelves

REF	Dimension			Loading surface		Weight	Load cap.	Wheel diam.
	mm			mm				
	a	b	c	d	e			
120TA9825	910	500	1524	850	500	44,0	250	160
120TA9826	1060	600	1524	1000	600	55,0	250	160
147TA3490	1060	700	1524	1000	700	61,0	250	160
147TA3491	1260	800	1524	1200	800	74,0	250	160

Swivel castors with wheel brakes and foot guards for your safety.



Also available as ESD version on page 27

Shelf trolley REF 120TA9825

### Additional Articles for shelf trolleys

REF	Dimension	for Loading surface	Weight	Load cap.	
	mm	mm			
161TA6202	845 x 485	850 x 500	6,5	80	Extra shelf
161TA6203	995 x 585	1000 x 600	8,5	80	Extra shelf
161TA6611	995 x 685	1000 x 700	12,5	80	Extra shelf
161TA6614	1195 x 785	1200 x 800	17,0	80	Extra shelf
161TA6341	815 x 455 x 45	850 x 500	7,0	80	Extra tray
161TA6342	965 x 555 x 45	1000 x 600	9,0	80	Extra tray
161TA6610	965 x 655 x 45	1000 x 700	11,0	80	Extra tray
161TA6613	1156 x 755 x 45	1200 x 800	15,0	80	Extra tray

### Shelf trolleys with 5 shelves

REF	Dimension			Loading surface		Weight	Load cap.	Wheel diam.
	mm			mm				
	a	b	c	d	e			
120TA9827	910	500	1524	850	500	56,0	250	160
120TA9828	1060	600	1524	1000	600	69,5	250	160
161TA6502	1060	700	1524	1000	700	81,5	250	160
161TA6525	1260	800	1524	1200	800	102,0	250	160

Swivel castors with wheel brakes and foot guards for your safety.



Also available as ESD version on page 27

Shelf trolley REF 120TA9827

### Shelf trolleys with 3 trays

REF	Dimension			Loading surface		Weight	Load cap.	Wheel diam.
	mm			mm				
	a	b	c	d	e			
120TA9829	910	500	1524	815	455	47,5	250	160
120TA9830	1060	600	1524	965	555	57,0	250	160
161TA6503	1060	700	1524	965	655	66,0	250	160
161TA6526	1260	800	1524	1165	755	80,0	250	160

Swivel castors with wheel brakes and foot guards for your safety.



Shelf trolley REF 120TA9829

### Shelf trolleys with 5 trays

REF	Dimension			Loading surface		Weight	Load cap.	Wheel diam.
	mm			mm				
	a	b	c	d	e			
120TA9831	910	500	1524	815	455	60,5	250	160
120TA9832	1060	600	1524	965	555	74,5	250	160
161TA6504	1060	700	1524	965	655	87,0	250	160
161TA6527	1260	800	1524	1165	755	108,0	250	160

Swivel castors with wheel brakes and foot guards for your safety.



Shelf trolley REF 120TA9831



# Shelf trolleys with sloping shelves

## Shelf trolleys with sloping shelves

Modular system; base structure with innovative frame section; Variable shelves of mesh 50 x 50 mm in angle-steel frame or base and shelves of wood-based, edge 15 mm high; for sloping or horizontal insertion; Shelf support interval 120 mm, gradient when sloping 15 degrees; Tubular pushbar welded to one end; Trolley powder-coated RAL 5010 gentian blue; permanent surface protection; impact- and scratch-resistant; Grey non-marking thermoplastic rubber tyres with precision deep-groove ball bearings; thread and foot guard; 2 swivel castors with wheel brakes and 2 fixed castors



Shelf trolley  
REF 161TA6462

Shelf trolley  
REF 120TA9849

Shelf trolley  
REF 161TA6461



### Shelf trolleys with 2 mesh shelves, galvanised

REF	Dimension			Loading surface		Weight	Load cap.	Wheel diam.
	a	b	c	d	e			
161TA6462	1508	550	1231	1320	537	53,5	250	160
161TA6489	1758	650	1271	1570	637	61,5	400	200

### Shelf trolleys with 2 wood shelves

120TA9849	1508	550	1231	1320	537	54,5	250	160
120TA9850	1758	650	1271	1570	637	65,0	400	200

### Shelf trolleys with 2 mesh shelves

161TA6461	1508	550	1231	1320	537	53,5	250	160
161TA6488	1758	650	1271	1570	637	61,5	400	200

Swivel castors with wheel brakes and foot guards for your safety.



Shelf trolley  
REF 161TA6464

Shelf trolley  
REF 120TA9851

Shelf trolley  
REF 161TA6463



### Shelf trolleys with 3 mesh shelves, galvanised

REF	Dimension			Loading surface		Weight	Load cap.	Wheel diam.
	a	b	c	d	e			
161TA6464	1508	550	1531	1320	537	66,0	250	160
161TA6491	1758	650	1571	1570	637	76,0	400	200

### Shelf trolleys with 3 wood shelves

120TA9851	1508	550	1531	1320	537	69,0	250	160
120TA9852	1758	650	1571	1570	637	84,0	400	200

### Shelf trolley with 3 mesh shelves

161TA6463	1508	550	1531	1320	537	66,0	250	160
161TA6490	1758	650	1571	1570	637	76,0	400	200

Swivel castors with wheel brakes and foot guards for your safety.

### Additional Articles for Shelf trolleys

REF	Dimension	Weight	Load cap.	
	mm	kg	kg	
161TA6604	1320 x 537	11,0	50	Extra shelf
161TA6608	1570 x 637	12,0	50	Extra shelf

### Additional Articles for Shelf trolley, galvanised

161TA6605	1320 x 537	11,0	50	Extra shelf
161TA6609	1570 x 637	12,0	50	Extra shelf

### Additional Articles for shelf trolley

120TA9855	1320 x 537	12,5	80	Extra shelf
120TA9856	1570 x 637	16,0	80	Extra shelf

### Shelf trolleys with 4 mesh shelves, galvanised

REF	Dimension			Loading surface		Weight	Load cap.	Wheel diam.
	a	b	c	d	e			
161TA6460	1508	550	1811	1320	537	77,0	250	160
161TA6487	1758	650	1851	1570	637	90,0	400	200

### Shelf trolleys with 4 wood shelves

120TA9853	1508	550	1811	1320	537	84,0	250	160
120TA9854	1758	650	1851	1570	637	102,5	400	200

### Shelf trolleys with 4 mesh shelves

161TA6459	1508	550	1811	1320	537	77,0	250	160
161TA6486	1758	650	1851	1570	637	90,0	400	200

Swivel castors with wheel brakes and foot guards for your safety.



Shelf trolley  
REF 161TA6460

Shelf trolley  
REF 120TA9853

Shelf trolley  
REF 161TA6459



# Serving trolley / Order-picking trolley



## Serving trolley

Welded tubular steel and innovative frame section; One pushbar at each end; glass shelves set in frame; Trolley surface galvanised; Grey non-marking thermoplastic rubber tyres with precision deep-groove ball bearings; 4 bolt-hole swivel castors

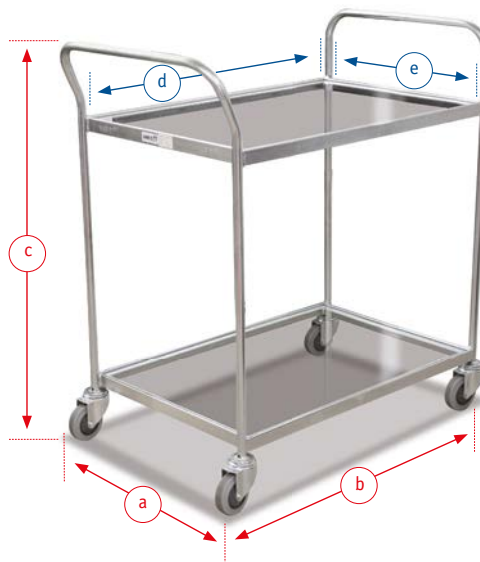

### Serving trolleys with 2 load surfaces

REF	Dimensions			Load surface		Weight	Load cap.	Wheel diam.
	mm			mm				
	a	b	c	d	e			
147TA3492	960	600	1050	850	600	38	100	100

Base and shelves of glass

Serving trolley  
REF 147TA3492

## Order-picking trolley with EasySTOP

Modular system; Base structure with innovative frame section; Load surface of plywood panel, screen-printed surface; Removable shelves for variable insertion at 50 mm intervals; capacity per shelf 60 kg; wire-mesh ends 50 x 50 mm; drawbar and coupling; Trolley surface galvanised; Grey non-marking thermoplastic rubber tyres with precision deep-groove ball bearings, thread guard and foot guard, 2 **EasySTOP** swivel castors and 2 fixed castors.



Information on page 7

### Additional parts on option



Steps press down in use



Middle wheel on option: 4 swivel castors combined with a middle castor and the trolley turns on spot.



Wire mesh shelf on option: Shelf support interval 50 mm



### Order-picking trolley with 4 load surfaces

REF	Dimensions			Load surface		Weight	Load cap.	Wheel diam.
	mm			mm				
	a	b	c	d	e			
161TA6804	1030	517	1776	850	500	68	400	160

Base and shelves of plywood, screen-printed surface



Order-picking trolley  
REF 161TA6804





# Document trolleys / Paper transport dollies



Document trolley  
REF 161TA6803

## Document trolley

Welded tubular steel; document compartment enclosed on 3 sides; Load surface inclined at 10° towards back; 1 pushbar at each end; Surface powder-coated RAL 7035 light grey; permanent surface protection; impact and scratch resistant; Four 100 mm thermoplastic swivel castors rubber with wheel brake

## Document trolley

REF	Dimensions			Load surface			Weight	Load cap.	Wheel diam.
	mm			mm					
	a	b	c	d	e	f	kg	kg	mm
161TA6803	600	525	1025	550	525	420	26	100	100

Load surface inclined at 10° towards back

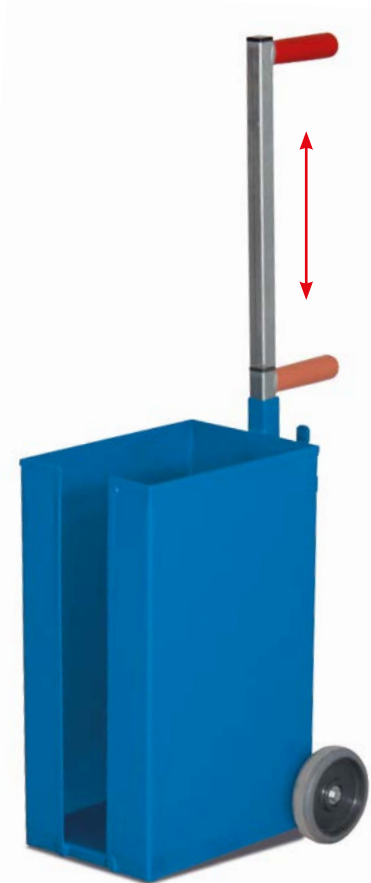

Paper transport dolly  
REF 161TA6792

## Paper transport dolly

Welded tubular steel; pushbar height adjustable; for A4 paper; Rubber-covered pushbar; Surface powder-coated RAL 5010 gentian blue; permanent surface protection; impact- and scratch-resistant; 2x 125 mm thermoplastic rubber castors with precision deep-groove ball bearings



## Paper transport dolly

REF	Dimensions			Load surface	Weight	Load cap.	Wheel diam.
	mm						
	a	b	c	mm	kg	kg	mm
161TA6792	210	300	1000	DIN A4	9	50	125

Adjustable-height pushbar

# Document trolleys



**VARIOfit**  
The perfect form  
of transport

## Document trolley with 20 compartments with EasySTOP

Robust welded steel construction; with 10 compartments at each end; tilt 5°; Central wall with mesh 70 x 70 mm and side walls of perforated sheet; With 2 vertical pushbars (projecting 100 mm); roof; collision guard on base frame (30 x 7 mm); Trolley powder-coated RAL 5010 gentian blue; permanent surface protection; impact- and scratch-resistant; Grey non-marking thermoplastic rubber tyres with precision deep groove ball bearings; thread and foot guard; 2 **EasySTOP** swivel castors and 2 fixed castors

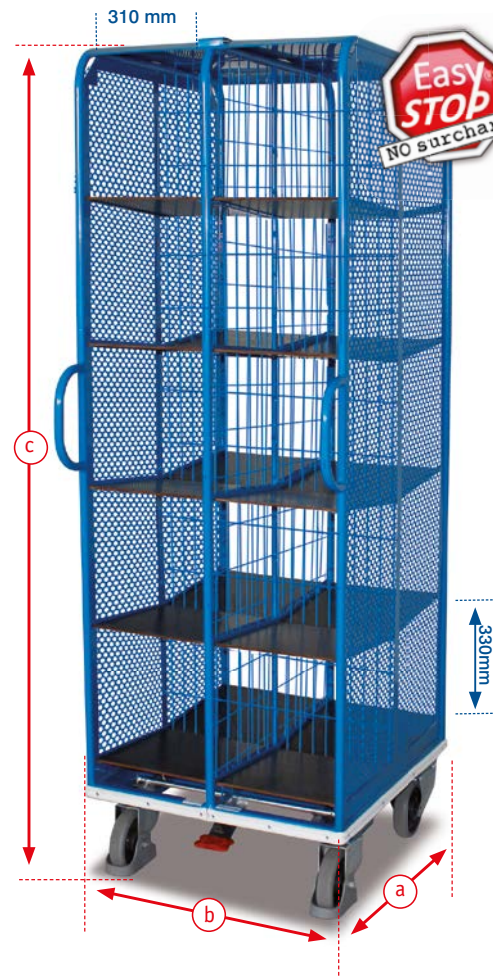

## Document trolley with 2 x 10 compartments width of compartment 310 mm

REF	Dimension			Loading surface	Weight	Load cap.	Wheel diam.
	mm						
	a	b	c				
161TA6805	575	860	2015	2 x 10 compartments	55,5	500	160

EasySTOP swivel castors and foot guards for your safety.

Document trolleys  
REF 161TA6805



## Document trolley with 9 compartments

Robust angle-steel construction; 9 compartments for files; Superstructure and compartments of wood-based board, surface finish beech; Recessed handle at end; base frame surrounded by protective plastic strip; Compartments can be closed by roller shutter with cylinder lock; Trolley powder-coated RAL 5010 gentian blue; permanent surface protection; impact- and scratch-resistant; Grey non-marking thermoplastic rubber tyres with precision deep-groove ball bearings; thread guard and foot guard; 2 swivel castors with wheel brakes and 2 fixed castors



## Document trolley with 9 compartments lockable

REF	Dimension			Loading surface	Weight	Load cap.	Wheel diam.
	mm						
	a	b	c	d	e		
161TA6440	877	474	1445	9 compartments	68,5	400	160

Swivel castors with wheel brakes and foot guards for your safety.

Document trolley  
REF 161TA6440

# Document trolley / Book trolley

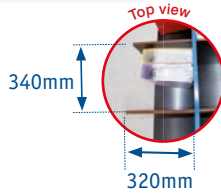

Document trolley  
REF 161TA6514

## Document trolley with 2 x 6 compartments with EasySTOP

Robust angle-steel construction; 6 compartments on each side; tilt 9°; Superstructure and compartments of waterproof bonded plywood; surface finish screen printed; With 2 top pushbars; base frame with surrounding protective strip of plastic profile; Trolley powder-coated RAL 5010 gentian blue; permanent surface protection; impact- and scratch-resistant; Grey non-marking thermoplastic rubber tyres with precision deep-groove ball bearings; thread and foot guard; 2 **EasySTOP** swivel castors and 2 fixed castors



Information on page 7

## Document trolley with 2 x 6 compartments

REF	Dimension			Loading surface	Weight	Load cap.	Wheel diam.
	a	b	c				
161TA6514	1105	700	1170	2 x 6 compartments	55,5	400	200

**EasySTOP** swivel castors and foot guards for your safety.



Book trolley  
REF 161TA6661

## Book trolley

Welded steel construction; 3 sloping shelves for transport and storage of books; tilt 5°; Vertical distance between shelves 300 mm; 1 pushbar at each end; Powder-coated RAL 5010 gentian blue; permanent surface protection; impact- and scratch-resistant; Grey non-marking thermoplastic rubber tyres, 4 swivel castors including 2 with wheel brakes

## Book trolley with 3 shelves and 5° slope

A/ REF	Dimension			Loading surface		Weight	Load cap.	Wheel diam.
	a	b	c	d	e			
161TA6661	900	300	890	830	290	26	150	75

**Swivel castors with wheel brakes!**



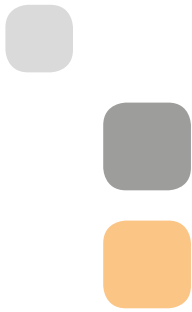

# Trolleys



# Workshop trolleys



VARIOfit®





# Workshop trolleys



Workshop trolley  
REF 120TA9867

**Drawer divider dimension inside:**

Typ 1 290 x 473 x 98 mm Typ 2 290 x 473 x 160 mm Typ 3 290 x 473 x 135 mm



**Workshop trolley with 1 cupboard, 4 drawers and 1 load surface (Drawer divider type 1, 2, 3)**

REF	Dimension			Loading surface		Weight	Load cap.	Wheel diam.
	mm			mm				
	a	b	c	d	e			
120TA9867	1111	600	960	1000	600	63,0	400	160

EasySTOP swivel castors and foot guards for your safety.



Workshop trolley  
REF 120TA9868



**Workshop trolley with 1 cupboard, 6 drawers and 1 load surface (Drawer divider type 6 x 1)**

REF	Dimension			Loading surface		Weight	Load cap.	Wheel diam.
	mm			mm				
	a	b	c	d	e			
120TA9868	1111	600	960	1000	600	69,0	400	160

EasySTOP swivel castors and foot guards for your safety.



Workshop trolley  
REF 161TA6598



**Additional Articles Pegboard tool panel (for Article on pages 46 - 48)**

REF	Dimension		Weight
	mm		
161TA6598	1000 x 588	for workshop trolley, with retaining edge	7,5
161TA6599	1000 x 588	for workshop trolley	10,0

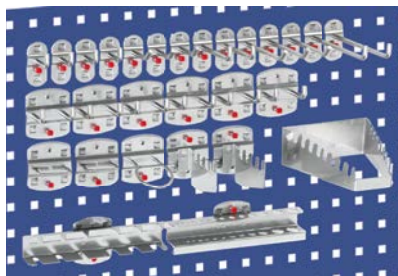

Holder selection 28 parts  
REF 161TA6601

**Additional Articles - Holder selection**

REF 161TA6601		28 parts
6x	Tool holder with rising end	
8x	Tool holder with vertical end	
6x	Double tool holder	
2x	Holder for pliers	
1x	Machine holder	
1x	Spanner holder	
1x	Screwdriver holder	
1x	Drill holder	
2x	Saw holder	

**Additional Articles - Holder selection**

REF 161TA6600		18 parts
5x	Tool holder with rising end	
2x	Tool holder with vertical end	
3x	Double tool holder	
3x	Tool clamp	
2x	Holder for pliers	
1x	Drill holder	
1x	Spanner holder	
1x	Screwdriver holder	



Material crate  
REF 161TA6405

**Additional Articles - Material crate**

REF		Size	Color
		mm	
161TA6405	Material crate	230 x 140 x 130	red
161TA6406	Material crate	290 x 140 x 130	blue
161TA6399	Material crate	85 x 105 x 45	green
161TA6400	Material crate	160 x 105 x 75	yellow



### Workshop trolleys with EasySTOP

Sheet steel construction; Working surface of beech finish plywood; 80 mm high surround on three sides; Front powder-coated RAL 5010 gentian blue; body RAL 7035 light grey; Cupboards with 1 fixed and 2 variable shelves; Drawers with sliding runners; with cylinder lock; Carrying capacity 30 kg per cupboard shelf and 25 kg per drawer; Grey non-marking thermoplastic rubber tyres with precision deepgroove ball bearings; thread and foot guard; 2 **EasySTOP** swivel castors and 2 fixed castors; Working height 915 mm



#### Workshop trolley with 1 cupboard, 4 drawers and 1 load surface (Drawer divider type 1, 2, 3)

REF	Dimension			Loading surface		Weight	Load cap.	Wheel diam.
	mm			mm				
	a	b	c	d	e			
120TA9869	1123	612	1040	1000	600	69,5	400	160

EasySTOP swivel castors and foot guards for your safety.



Workshop trolley  
REF 120TA9869

What is **EasySTOP** and what makes it so special? Information on page 7



#### Workshop trolley with 1 cupboard, 6 drawers and 1 load surface (Drawer divider type 6 x 1)

REF	Dimension			Loading surface		Weight	Load cap.	Wheel diam.
	mm			mm				
	a	b	c	d	e			
120TA9870	1123	612	1040	1000	600	75,5	400	160

EasySTOP swivel castors and foot guards for your safety.



Workshop trolley  
REF 120TA9870

#### Additional Articles

REF	Dimension	Weight
161TA6616	1, 2, 3	1,5

Drawer divider set for products on pages 46 - 47 (except sw-500.014)



Drawer divider set  
REF 161TA6616

#### Cabinet with hinged door and 1 load surface

REF	Dimension			Loading surface		Weight	Load cap.	Wheel diam.
	mm			mm				
	a	b	c	d	e			
120TA9871	575	660	910	551	638	33,5	150	125

EasySTOP swivel castors and foot guards for your safety.



Cabinet  
REF 120TA9871

Drawer divider dimension inside:  
Typ 4 390 x 535 x 98 mm Typ 5 390 x 535 x 157 mm

#### Cabinet with 4 drawers and 1 load surface (Drawer divider type 3 x 4, 5)

REF	Dimension			Loading surface		Weight	Load cap.	Wheel diam.
	mm			mm				
	a	b	c	d	e			
120TA9872	575	660	910	551	638	50,0	150	125

EasySTOP swivel castors and foot guards for your safety.



Cabinet  
REF 120TA9872



\*similar to figure



# Workshop trolleys

**VARIOfit**  
The perfect form  
of transport

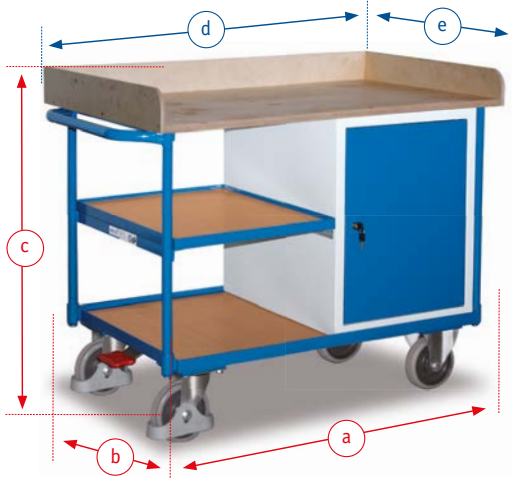

Workshop trolley  
REF 120TA9863

## Workshop trolleys with EasySTOP

Made of steel section/tubular steel; Working surface of beech finish plywood; 80 mm high surround on three sides; Front powder-coated RAL 5010 gentian blue; body RAL 7035 light grey; Cupboards with 1 fixed and 2 variable shelves; Drawers with sliding runners; with cylinder lock; Carrying capacity 30 kg per cupboard shelf and 25 kg per drawer; Grey non-marking thermoplastic rubber tyres with precision deep-groove ball bearings; thread and foot guard; 2 **EasySTOP** swivel castors and 2 fixed castors; Usable height 800 mm

### Workshop trolley with 1 cupboard and 3 load surfaces

REF	Dimension			Loading surface		Weight	Load cap.	Wheel diam.
	mm			mm				
	a	b	c	d	e	kg	kg	mm
120TA9863	1218	640	960	1126	628	66,0	400	160

EasySTOP swivel castors and foot guards for your safety.



Workshop trolley  
REF 120TA9864

### Workshop trolley with 1 cupboard, 1 drawer and 1 load surface

REF	Dimension			Loading surface		Weight	Load cap.	Wheel diam.
	mm			mm				
	a	b	c	d	e	kg	kg	mm
120TA9864	1218	640	960	1126	628	64,5	400	160

EasySTOP swivel castors and foot guards for your safety.

### Drawer divider dimension inside:

Typ 4 390 x 535 x 98 mm Typ 5 390 x 535 x 157 mm



Workshop trolley  
REF 120TA9865

### Workshop trolley with 4 drawers and 3 load surfaces (Drawer divider type 3 x 4, 5)

REF	Dimension			Loading surface		Weight	Load cap.	Wheel diam.
	mm			mm				
	a	b	c	d	e	kg	kg	mm
120TA9865	1218	640	960	1126	628	81,5	400	160

EasySTOP swivel castors and foot guards for your safety.



Workshop trolley  
REF 120TA9866

### Workshop trolley with 1 cupboard, 4 drawers and 1 load surface (Drawer divider type 3 x 4, 5)

REF	Dimension			Loading surface		Weight	Load cap.	Wheel diam.
	mm			mm				
	a	b	c	d	e	kg	kg	mm
120TA9866	1218	640	960	1126	628	93,5	400	160

EasySTOP swivel castors and foot guards for your safety.



### Workshop trolleys with EasySTOP

Made of steel section/tubular steel; Working surface of beech finish plywood; Front powder-coated RAL 5010 gentian blue; body RAL 7035 light grey; Cupboards with 1 fixed and 2 variable shelves; Drawers with sliding runners; with cylinder lock; Carrying capacity 30 kg per cupboard shelf and 25 kg per drawer; Grey non-marking thermoplastic rubber tyres with precision deep-groove ball bearings; thread and foot guard; 2 **EasySTOP** swivel castors and 2 fixed castors

#### Workshop trolley with 3 load surfaces and 1 cupboard

REF	Dimension			Loading surface		Weight	Load cap.	Wheel diam.
	mm			mm				
	a	b	c	d	e			
120TA9857	1130	624	1013	1000	600	61,0	250	125

EasySTOP swivel castors and foot guards for your safety.



Workshop trolley  
REF 120TA9857

#### Workshop trolley with 2 cupboards

REF	Dimension			Loading surface		Weight	Load cap.	Wheel diam.
	mm			mm				
	a	b	c	d	e			
120TA9858	1130	624	1013	1000	600	73,5	250	125

EasySTOP swivel castors and foot guards for your safety.



Workshop trolley  
REF 120TA9858



Information on page 7

#### Workshop trolley with 3 load surfaces and 4 drawers (Drawer divider dimension 3 x 4, 5)

REF	Dimension			Loading surface		Weight	Load cap.	Wheel diam.
	mm			mm				
	a	b	c	d	e			
120TA9859	1130	624	1013	1000	600	76,5	250	125

EasySTOP swivel castors and foot guards for your safety.



Workshop trolley  
REF 120TA9859

#### Workshop trolley with 1 load surface, 4 drawers and 1 cupboard (Drawer divider type 3 x 4, 5)

REF	Dimension			Loading surface		Weight	Load cap.	Wheel diam.
	mm			mm				
	a	b	c	d	e			
120TA9860	1130	624	1013	1000	600	89,5	250	125

EasySTOP swivel castors and foot guards for your safety.



Workshop trolley  
REF 120TA9860

#### Workshop trolley with 1 load surface and 8 drawers (Drawer divider type 6 x 4, 2 x 5)

REF	Dimension			Loading surface		Weight	Load cap.	Wheel diam.
	mm			mm				
	a	b	c	d	e			
120TA9862	1130	624	1013	1000	600	106,5	250	125

EasySTOP swivel castors and foot guards for your safety.



Workshop trolley  
REF 120TA9862



# Workshop trolleys

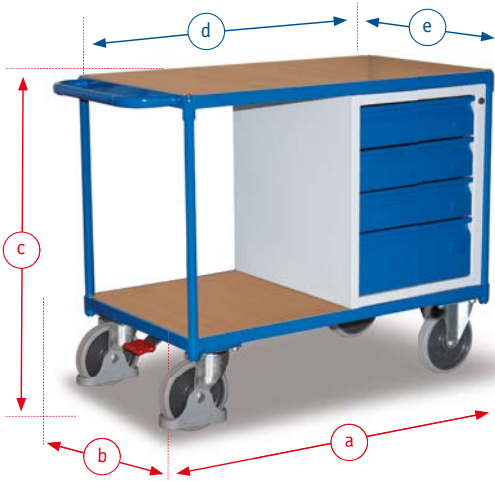

Workshop trolley  
REF 138TA3986

## Workshop trolleys with EasySTOP

Made of steel section/tubular steel; Working surface of beech finish plywood; Front powder-coated RAL 5010 gentian blue; body RAL 7035 light grey; Cupboards with 1 fixed and 2 variable shelves; Drawers with sliding runners; with cylinder lock; Carrying capacity 30 kg per cupboard shelf and 25 kg per drawer; Grey non-marking thermoplastic rubber tyres with precision deep-groove ball bearings; thread and foot guard; 2 **EasySTOP** swivel castors and 2 fixed castors

### Workshop trolley with 4 drawers and 2 load surfaces (Drawer divider type 3 x 4, 5)

REF	Dimension			Loading surface		Weight	Load cap.	Wheel diam.
	mm			mm				
	a	b	c	d	e			
138TA3986	1190	600	931	1060	600	80,5	500	200

**EasySTOP** swivel castors and foot guards for your safety.

### Drawer divider dimension inside:

**Typ 4** 390 x 535 x 98 mm **Typ 5** 390 x 535 x 157 mm



Workshop trolley  
REF 120TA9861

### Workshop trolley with 1 cupboard and 2 load surfaces

REF	Dimension			Loading surface		Weight	Load cap.	Wheel diam.
	mm			mm				
	a	b	c	d	e			
120TA9861	1190	600	931	1060	600	64,5	500	200

**EasySTOP** swivel castors and foot guards for your safety.



Workshop trolley  
REF 138TA3987

### Workshop trolley with 1 cupboard and 4 drawers (Drawer divider type 3 x 4, 5)

REF	Dimension			Loading surface		Weight	Load cap.	Wheel diam.
	mm			mm				
	a	b	c	d	e			
138TA3987	1190	600	931	1060	600	101,0	500	200

**EasySTOP** swivel castors and foot guards for your safety.



Workshop trolley  
REF 138TA3988

### Workshop trolley with 8 drawers (Drawer divider type 6 x 4, 2 x 5)

REF	Dimension			Loading surface		Weight	Load cap.	Wheel diam.
	mm			mm				
	a	b	c	d	e			
138TA3988	1190	600	931	1060	600	118,0	500	200

**EasySTOP** swivel castors and foot guards for your safety.



\*similar to figure



The perfect form of transport

VARIOfit®

### Workshop trolleys with EasySTOP

Made of steel section/tubular steel; Working surface of beech finish plywood; Front powder-coated RAL 5010 gentian blue; body RAL 7035 light grey; Cupboards with 1 fixed and 2 variable shelves; Drawers with sliding runners; with cylinder lock; Carrying capacity 30 kg per cupboard shelf and 25 kg per drawer; Grey non-marking thermoplastic rubber tyres with precision deep-groove ball bearings; thread and foot guard; 2 **EasySTOP** swivel castors and 2 fixed castors



Workshop trolley  
REF 161TA6484

#### Workshop trolley with 1 load surface and 1 cupboard with double door and T-handle lock

REF	Dimension			Loading surface		Weight	Load cap.	Wheel diam.
	mm			mm				
	a	b	c	d	e			
161TA6484	1125	624	1100	1000	600	61,0	250	125

EasySTOP swivel castors and foot guards for your safety.



What is **EasySTOP** and what makes it so special? Information on page 7

### Heavy-duty workshop trolley with EasySTOP

Made of steel section/tubular steel; Load surface of waterproof bonded plywood, surface finish screen printed, anti slip; Front powder-coated RAL 5010 gentian blue; body RAL 7035 light grey; Elastic solid rubber tyres on cast aluminium wheels; ball-bearing hubs; foot guards; 2 **EasySTOP** swivel castors and 2 fixed castors



Heavy-duty workshop trolley  
REF 161TA6512

#### Heavy-duty workshop trolleys with 2 load surfaces and 1 cupboard

REF	Dimension			Loading surface		Weight	Load cap.	Wheel diam.
	mm			mm				
	a	b	c	d	e			
161TA6512	1190	700	931	1060	700	73,5	1000	200
161TA6691	1390	800	931	1260	800	100,0	1000	200

EasySTOP swivel castors and foot guards for your safety.

#### Additional Articles

REF	Dimension	Weight
161TA6370	4,5	2,5



a 25 mm b 120 mm



Drawer divider set  
REF 161TA6370



# Table trolleys with pan



Table trolley  
REF 120TA9882

## Table trolleys with pan and EasySTOP

Welded steel construction; Oil-tight pans; Trolley powder-coated RAL 5010 gentian blue; permanent surface protection; impact resistant and scratch-resistant; Grey non-marking thermoplastic rubber tyres with precision deep-groove ball bearings; thread and foot guard; 2 **EasySTOP** swivel castors and 2 fixed castors



### Table trolleys with 2 levels, pan sides 40 mm high

REF	Dimension			Loading surface		Weight	Load cap.	Wheel diam.
	mm			mm				
	a	b	c	d	e			
120TA9882	980	500	910	846	496	36,0	400	160
121TA1029	1135	700	955	996	696	46,5	400	200

EasySTOP swivel castors and foot guards for your safety.



Table trolley  
REF 120TA9883



### Table trolleys with 3 levels, bolted pans, sides 40 mm high

REF	Dimension			Loading surface		Weight	Load cap.	Wheel diam.
	mm			mm				
	a	b	c	d	e			
120TA9883	980	500	910	846	496	36,0	400	160
120TA9884	1135	700	955	996	696	46,5	400	200

EasySTOP swivel castors and foot guards for your safety.



Table trolley  
REF 161TA6667



What is **EasySTOP** and what makes it so special? Information on page 7

### Table trolleys with 2 levels, bolted pans, sides 40 mm high

REF	Dimension			Loading surface		Weight	Load cap.	Wheel diam.
	mm			mm				
	a	b	c	d	e			
161TA6667	980	500	1060	846	496	36,0	400	160
161TA6683	1135	700	1105	996	696	46,5	400	200

EasySTOP swivel castors and foot guards for your safety.



Table trolley  
REF 161TA6670

### Table trolleys with 3 levels, bolted pans, sides 40 mm high

REF	Dimension			Loading surface		Weight	Load cap.	Wheel diam.
	mm			mm				
	a	b	c	d	e			
161TA6670	980	500	1060	846	496	36,0	400	160
161TA6685	1135	700	1105	996	696	46,5	400	200

EasySTOP swivel castors and foot guards for your safety.



Environmentally safe storage of substances dangerous to water

Table trolley with 2 levels, top steel-sheet pan removable, sides 200 mm high, with reinforced edges and 2 handles

REF	Dimension			Loading surface		Weight	Load cap.	Wheel diam.
	mm			mm				
	a	b	c	d	e	kg	kg	mm
120TA9886	1164	610	1042	983	583	46,5	250	125

Swivel castors with wheel brakes and foot guards for your safety.



Table trolley  
REF 120TA9886

Table trolley with 2 levels, bolted pans, sides 25 mm high

REF	Dimension			Loading surface		Weight	Load cap.	Wheel diam.
	mm			mm				
	a	b	c	d	e	kg	kg	mm
120TA9885	1157	610	830	996	596	36,0	250	125

Swivel castors with wheel brakes and foot guards for your safety.



Table trolley  
REF 120TA9885



Environmentally safe storage of substances dangerous to water

Table trolley with 2 levels, galvanised grating, mesh size 30 x 30 mm, and drip tray. Top pan 100 mm with conical drain cock "

REF	Dimension			Loading surface		Weight	Load cap.	Wheel diam.
	mm			mm				
	a	b	c	d	e	kg	kg	mm
120TA9887	1125	610	993	997	597	59,0	250	125

Swivel castors with wheel brakes and foot guards for your safety.



Table trolley  
REF 120TA9887



**VARIOfit**<sup>®</sup>



**Tubular-support trolleys**



**Sheet-material trucks**



# Sheet-material trucks



VARIOfit®  
The perfect form of transport

## Sheet-material trucks

Welded tubular steel construction; sheet-steel platform; Toe plate sloping towards supporting frame, welded to substructure; Tilt 22°; Powder-coated RAL 5010 gentian blue; permanent surface protection; impact-and scratch-resistant; Pneumatic or solid-rubber tyres, plus 2 support rollers; Also available: Version with variable panel retainer; for panel stack max. 200 x 1.500 mm (D/H)



### Sheet-material trucks

REF		Dimension					Loading surface mm	Weight kg	Load cap. kg	Wheel diam. mm
		a	b	c	d	e				
138TA4001	P	1260	680	1435	500	200	17,0	250	260 × 85	
138TA4002	SR	1260	680	1435	500	200	21,5	250	250 × 60	

P = pneumatic tyres, SR = solid-rubber tyres

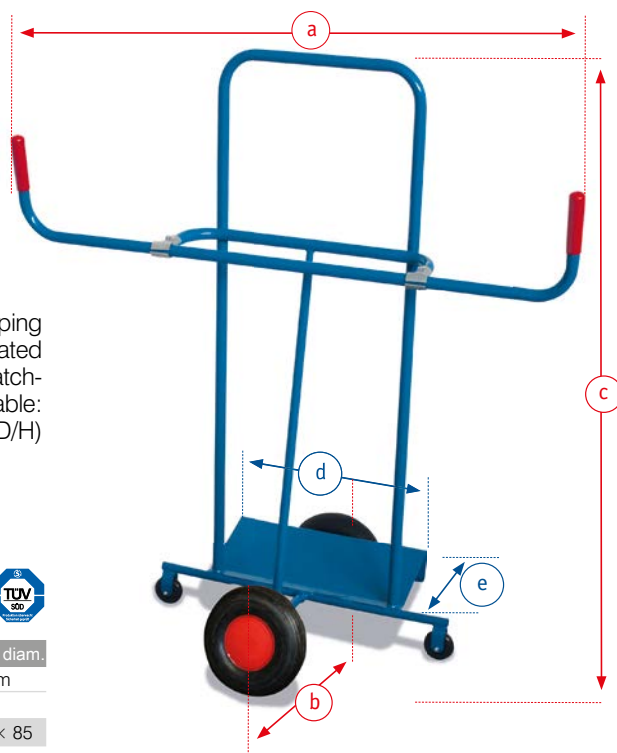

Sheet-material truck  
REF 138TA4001



for all trucks

Info Page 11, 77

### Sheet-material trucks with panel retainer

REF		Dimension					Loading surface mm	Weight kg	Load cap. kg	Wheel diam. mm
		a	b	c	d	e				
161TA6423	P	1260	680	1439	500	200	21,5	250	260 × 85	
161TA6424	SR	1260	680	1439	500	200	25,5	250	250 × 60	

P = pneumatic tyres, SR = solid-rubber tyres

Sheet-material truck  
REF 161TA6423



# Sheet-material trolleys / Sheet-material stands



Sheet-material trolley  
REF 138TA3991

#### Additional Articles

REF	Height mm	Length mm	
147TA3493	300	1200 mm	Tubular-support
147TA3494	600	1200 mm	
147TA3495	900	1200 mm	
161TA6270	300	1600 mm	
161TA6271	600	1600 mm	
161TA6272	900	1600 mm	

#### Feet for Sheet-material stand

161TA6219	Ground clearance 100 mm
-----------	-------------------------



Sheet-material stand  
REF 138TA3989



Tubular-support trolley  
REF 121TA1030



Tubular-support  
REF 129TA5643

#### Sheet-material trolleys

Welded steel construction; without tubular supports; 7 alternative positions for inserting tubular supports; clearance between supports 90 mm; Load surface of wood-based board, surface finish beech; Trolley powder-coated RAL 5010 gentian blue; permanent surface protection; impact-resistant and scratch-resistant; Grey non-marking thermoplastic rubber tyres with precision deep-groove ball bearings; thread and foot guard; 2 swivel castors with wheel brakes and 2 fixed castors; For 1200 kg carrying capacity; elastic tyres on aluminium rim with ballbearing hubs

#### Sheet-material trolleys without tubular supports

REF	Dimension mm	Loading surface mm	Weight kg	Load cap. kg	Wheel diam. mm			
						a	b	c
138TA3991	TR 1307	800	308	1200	800	41,5	500	200
138TA3992	ER 1307	800	308	1200	800	46,0	1200	200
138TA3993	TR 1707	800	308	1600	800	47,5	500	200
138TA3994	ER 1707	800	308	1600	800	52,5	1200	200

Swivel castors with wheel brakes and foot guards for your safety

TR = Thermoplastic rubber tyres, ER = Elastic rubber tyres

#### Sheet-material stands without tubular supports

Description as for sheet-material trolley, but without castors; One approach roller at end

#### Sheet-material stand without tubular supports.

REF	Dimension mm			Loading surface mm		Weight kg	Load cap. kg
	a	b	c	d	e		
138TA3989	1307	800	75	1200	800	33,5	1200
138TA3990	1707	800	75	1600	800	39,5	1200



## Tubular-support trolleys

#### Tubular-support trolley

Modular system; Base structure with innovative frame section; Load surface of wood-based board, surface finish beech; incl. 2 tubular supports and 2 rows of sockets for 7 tubular supports; Trolley powder-coated RAL 5010 gentian blue; permanent surface protection; impact- and scratch-resistant; Grey non-marking thermoplastic rubber tyres with precision deep-groove ball bearings; thread and foot guard; 2 swivel castors with wheel brakes and 2 fixed castors

#### Tubular-support trolleys

REF	Dimension mm			Loading surface mm		Weight kg	Load cap. kg	Wheel diam. mm
	a	b	c	d	e			
121TA1030	1140	700	1041	1073	640	42,0	500	200
121TA1031	1340	800	1041	1273	740	48,0	500	200

Swivel castors with wheel brakes and foot guards for your safety.

#### Additional Articles

REF		Weight kg
129TA5643	Additional tube for 1073 × 640 mm	5,5
129TA5644	Additional tube for 1273 × 740 mm	5,5





### Sheet-material trolleys

Welded steel construction; one-sided or two-sided load surface; Sheet supports faced with rubber profile; Load surface tilts to 6°; Trolley powder-coated RAL 5010 gentian blue; permanent surface protection; impact and scratch-resistant; Elastic tyres with ball bearings; thread and foot guard; 2 swivel castors with wheel brakes and 2 fixed castors.

#### Sheet-material trolleys, one-sided, base support width 430 mm

REF	Dimension			Loading surface		Weight	Load cap.	Wheel diam.
	mm			mm				
	a	b	c	d	e			
138TA3995	1380	880	1700	1380	430	57,0	1200	200
138TA3996	1680	880	1700	1680	430	62,0	1200	200
138TA3997	2080	880	1700	2080	430	85,0	1200	200

Swivel castors with wheel brakes and foot guards for your safety.



Sheet-material trolley  
REF 138TA3995

#### Sheet-material trolleys, two-sided, base support width 2 x 270 mm

REF	Dimension			Loading surface		Weight	Load cap.	Wheel diam.
	mm			mm				
	a	b	c	d	e			
138TA3998	1380	880	1700	1380	2 x 270	71,0	1200	200
138TA3999	1680	880	1700	1680	2 x 270	78,0	1200	200
138TA4000	2080	880	1700	2080	2 x 270	98,0	1200	200

Swivel castors with wheel brakes and foot guards for your safety.



Sheet-material trolley  
REF 138TA3998

### Sheet-material trolleys

Welded steel construction; load surface of plywood, tilts to 5°; Trolley powder-coated RAL 5010 gentian blue; permanent surface protection; impact- and scratch-resistant; Grey non-marking thermoplastic rubber tyres with precision deep-groove ball bearings; thread and foot guard; 2 swivel castors with wheel brakes and 2 fixed castors; Also available with rhombic layout

#### Sheet-material trolley with board load surface, side-frame height 930 mm

REF	Dimension			Loading surface		Weight	Load cap.	Wheel diam.
	mm			mm				
	a	b	c	d	e			
161TA6418	1500	680	1200	1500	370	48,5	500	200

Swivel castors with wheel brakes and foot guards for your safety.



Sheet-material trolley  
REF 161TA6418

#### Sheet-material trolley with board load surface, side-frame height 930 mm, rhombic wheel layout

REF	Dimension			Loading surface		Weight	Load cap.	Wheel diam.
	mm			mm				
	a	b	c	d	e			
161TA6419	1500	680	1200	1500	370	48,5	500	200

Swivel castors with wheel brakes and foot guards for your safety.



Sheet-material trolley  
REF 161TA6419



# Workpiece trolleys

## Workpiece trolley

Modular system; Base structure with innovative frame section; Load surface of wood-based board, surface finish beech; Superstructure made of angle steel with welded mesh 75 x 75 mm; Slope of grid 8%; height of superstructure 1265 mm; Trolley powder-coated RAL 5010 gentian blue; permanent surface protection; impact- and scratch-resistant; Grey non-marking thermoplastic rubber tyres with precision deep-groove ball bearings; thread and foot guard; 2 swivel castors with wheel brakes and 2 fixed castors



Workpiece trolley with top shelf  
REF 161TA6210

Workpiece trolley  
REF 161TA6181



### Workpiece trolley without top shelf

REF	Dimension			Weight	Load cap.	Wheel diam.
	mm					
	a	b	c			
161TA6181	1370	800	1553	90,5	500	200

### Workpiece trolley with top shelf, 1174 x 264 mm (W/D)

161TA6210	1370	800	1578	98,0	500	200
-----------	------	-----	------	------	-----	-----

Swivel castors with wheel brakes and foot guards for your safety.



Thorn bracket  
REF 161TA6182



Pipe carrier  
REF 161TA6195



Corrugated bracket  
REF 161TA6198



Forked bracket  
REF 161TA6199



Material box  
REF 161TA6200

### Additional Articles | Thorn bracket

REF	Dimension	Weight	Load cap.
161TA6182	10 diam. × 200	0,30	10
161TA6183	10 diam. × 300	0,40	10

### Additional Articles | Pipe carrier

REF	Dimension	Weight	Load cap.
161TA6195	16 diam. × 300	0,35	15
161TA6196	22 diam. × 300	0,45	25
161TA6197	27 diam. × 300	0,55	25

### Additional Articles | Corrugated bracket

REF	Dimension	Weight	Load cap.
161TA6198	320	0,80	25

### Additional Articles | Forked bracket

REF	Dimension	Weight	Load cap.
161TA6199	50 LW × 300	0,75	25

### Additional Articles | Material box

REF	Dimension	Weight	Load cap.
161TA6200	250 × 150 × 80	1,50	25
161TA6201	1200 × 250 × 40	4,50	50

For more material crate variants and sizes, see page 46

### Additional Articles - material crate

REF	Size	Color	
			mm
161TA6405	material crate	230 x 140 x 130	red



Material crate  
REF 161TA6405

# Order-picking trolleys



## Order-picking trolleys

Welded steel construction; Panels of wood-based board; surface finish beech; load surface edge 15 mm high; Trolley powder-coated RAL 5010 gentian blue; permanent surface protection; impact- and scratch-resistant. Grey non-marking thermoplastic rubber tyres with precision deep-groove ball bearings; thread and foot guard; 2 swivel castors with wheel brakes and 2 fixed castors

### Order-picking trolley with 2 shelves

REF	Dimension			Loading surface		Weight	Load cap.	Wheel diam.
	a	b	c	d	e			
138TA3979	1320	600	1135	990	590	46,0	250	125

shelf heights 190/820mm  
height of top step 515mm  
step height 235mm

Swivel castors with wheel brakes and foot guards for your safety.

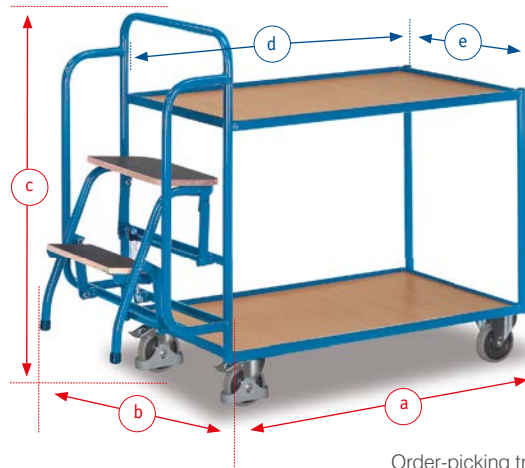

Order-picking trolley  
REF 138TA3979

### Order-picking trolley with 3 shelves

REF	Dimension			Loading surface		Weight	Load cap.	Wheel diam.
	a	b	c	d	e			
138TA3980	1320	600	1135	990	590	57,0	250	125

shelf heights 190/505/820 mm  
height of top step 515mm  
step height 235mm

Swivel castors with wheel brakes and foot guards for your safety.



Order-picking trolley  
REF 138TA3980

### Order-picking trolley with 3 shelves

REF	Dimension			Loading surface		Weight	Load cap.	Wheel diam.
	a	b	c	d	e			
138TA3981	1600	600	1900	990	590	71,0	250	160

shelf heights 240/860/1480 mm  
height of top step 935 mm  
step height 235 mm

Swivel castors with wheel brakes and foot guards for your safety.



Order-picking trolley  
REF 138TA3981

### Order-picking trolley with 4 shelves

REF	Dimension			Loading surface		Weight	Load cap.	Wheel diam.
	a	b	c	d	e			
138TA3982	1600	600	1900	990	590	83,0	250	160

shelf heights 240/715/1190/1665mm  
height of top step 935mm  
step height 230mm

Swivel castors with wheel brakes and foot guards for your safety.



Order-picking trolley  
REF 138TA3982





# Carrier spar trolleys

## Carrier spar trolleys

Welded tubular steel construction; 8 or 12 carrier spars per side; Width of trolley continuously adjustable; Height of carrier spars continuously adjustable; Scale for adjusting arrangement of carrier spars; Powder-coated RAL 5010 gentian blue; permanent surface protection; impact- and scratch-resistant; Grey non-marking thermoplastic rubber tyres with precision deep-groove ball bearings; thread and foot guard; 4 swivel castors and 2 with wheel brakes

### Carrier-spar trolleys, one-sided, with 2 uprights

REF		Dimension			Weight	Load cap.	Wheel diam.
		mm					
		a	b	c	kg	kg	mm
161TA6431	one-sided	440-1300	800	1800	52,0	400	160
161TA6433	one-sided	440-1600	800	1800	53,5	400	160

Swivel castors with wheel brakes and foot guards for your safety.

Carrier spar trolley  
REF 161TA6431



### Scale

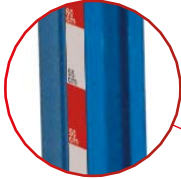

Carrier spar trolley  
REF 161TA6434



### Carrier-spar trolleys, two-sided, with 2 uprights

REF		Dimension			Weight	Load cap.	Wheel diam.
		mm					
		a	b	c	kg	kg	mm
161TA6432	two-sided	440-1300	832	1800	63,0	400	160
161TA6434	two-sided	560-1600	832	1800	65,0	400	160

Swivel castors with wheel brakes and foot guards for your safety.

### Additional Carrier-spar

REF	Dimension	Load cap.
-----	-----------	-----------

#### Carrier-spar length 596 mm

	mm		kg
161TA6709	596mm x 3/4"	Carrier-spar	20
161TA6710	596mm x 3/4"	Carrier-spar with shrink hose	20
161TA6711	1mm	Shrink hose	-
161TA6712	596mm x 3/4"	Carrier-spar with slip off safety	20
161TA6702	∅ 70 mm	Slip off safety	-
161TA6713	596mm x 3/4"	Carrier-spar with shrink hose and anti-roll devices	20

#### Carrier-spar length 376 mm

161TA6704	376mm x 3/4"	Carrier-spar	20
161TA6705	376mm x 3/4"	Carrier-spar with shrink hose	20
161TA6706	1mm	Shrink hose	-
161TA6707	376mm x 3/4"	Carrier-spar with slip off safety	20
161TA6702	∅ 70 mm	Slip off safety	-
161TA6708	376mm x 3/4"	Carrier-spar with shrink hose and anti-roll devices	20

### Carrier-spar trolleys, one-sided, with 3 uprights

REF		Dimension			Weight	Load cap.	Wheel diam.
		mm					
		a	b	c	kg	kg	mm
161TA6435	one-sided	560-2100	800	1800	66,0	400	160
161TA6437	one-sided	560-3100	800	1800	71,5	400	160

Swivel castors with wheel brakes and foot guards for your safety.

Carrier spar trolley  
REF 161TA6435



### Carrier-spar trolleys, two-sided, with 3 uprights

REF		Dimension			Weight	Load cap.	Wheel diam.
		mm					
		a	b	c	kg	kg	mm
161TA6436	two-sided	560-2100	832	1800	83,0	400	160
161TA6438	two-sided	560-3100	832	1800	89,0	400	160

Swivel castors with wheel brakes and foot guards for your safety.

Carrier spar trolley  
REF 161TA6436



# Euro container trolleys



VARIOfit  
The perfect form  
of transport

## Euro container trolleys

Welded steel construction; Tilts to 17° or 32°; Shelves open or of wood-based board, surface finish beech; edge 10 mm high; Trolley powder-coated RAL 5010 gentian blue; permanent surface protection; impact- and scratch-resistant; Grey non-marking thermoplastic rubber tyres with precision deep-groove ball bearings; thread guards; 4 swivel castors with foot guards 2 with wheel brakes; Shelf heights: 265, 545, 845 mm

Floors tiltable

### Euro container trolley, 3 open shelves, Loading surface 410 mm

REF	Dimension			Loading surface		Weight	Load cap.	Wheel diam.
	mm			mm				
	a	b	c	d	e			
138TA4034	520	665	1125	410	604	32,5	200	125

### Euro container trolley, 3 open shelves, Loading surface 825 mm

138TA4037	935	665	1125	825	604	38,0	200	125
-----------	-----	-----	------	-----	-----	------	-----	-----

Swivel castors with wheel brakes and foot guards for your safety.

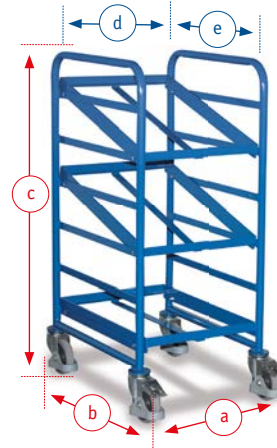

Euro container trolley  
REF 138TA4037

Euro container trolley  
REF 138TA4034

### Euro container trolley, 3 plastic crate (600 x 400 x 170 mm 35 liter), Loading surface 410 mm

REF	Dimension			Loading surface		Weight	Load cap.	Wheel diam.
	mm			mm				
	a	b	c	d	e			
138TA4035	520	665	1125	410	604	37,0	200	125

### Euro container trolley, 6 plastic crate (600 x 400 x 170 mm, 35 liter), Loading surface 825 mm

138TA4038	935	665	1125	825	604	47,0	200	125
-----------	-----	-----	------	-----	-----	------	-----	-----

Swivel castors with wheel brakes and foot guards for your safety.



Euro container trolley  
REF 138TA4038

Euro container trolley  
REF 138TA4035

### Euro container trolley, 3 wooden shelves, Loading surface 410 mm

REF	Dimension			Loading surface		Weight	Load cap.	Wheel diam.
	mm			mm				
	a	b	c	d	e			
138TA4036	520	665	1125	410	604	40,0	200	125

### Euro container trolley, wooden shelves, Loading surface 825 mm

138TA4039	935	665	1125	825	604	52,0	200	125
-----------	-----	-----	------	-----	-----	------	-----	-----

Swivel castors with wheel brakes and foot guards for your safety.



Euro container trolley  
REF 138TA4039

Euro container trolley  
REF 138TA4036



# Euro container trolleys



Euro container trolley  
REF 138TA4040

## Euro container trolleys

Welded steel construction; Tilts to 17° or 32°; Shelves open or of wood-based board, surface finish beech, edge 10 mm high; Trolley powder-coated RAL 5010 gentian blue; permanent surface protection; impact- and scratch-resistant; Grey non marking thermoplastic rubber tyres with precision deep-groove ball bearings; thread guards; 4 swivel castors with foot guards, 2 with wheel brakes; Shelf heights: 300, 600, 900, 1200, 1500 mm

Floors tiltable

### Euro container trolley, 5 open shelves

REF	Dimension			Loading surface		Weight	Load cap.	Wheel diam.
	mm			mm				
	a	b	c	d	e			
138TA4040	1350	665	1695	1240	604	70,5	250	160

Swivel castors with wheel brakes and foot guards for your safety.



Euro container trolley  
REF 138TA4041

### Additional Articles

REF	Dimension		Load cap.
	mm		
161TA6398	600 x 400 x 170		35
161TA6397	600 x 400 x 220		45

### Euro container trolley, 15 plastic crate 600 x 400 x 170 mm, 35 liter

REF	Dimension			Loading surface		Weight	Load cap.	Wheel diam.
	mm			mm				
	a	b	c	d	e			
138TA4041	1350	665	1695	1240	604	93,0	250	160

Swivel castors with wheel brakes and foot guards for your safety.



Euro container trolley  
REF 138TA4042

### Euro container trolley, 5 wooden shelves

REF	Dimension			Loading surface		Weight	Load cap.	Wheel diam.
	mm			mm				
	a	b	c	d	e			
138TA4042	1350	665	1695	1240	604	106,5	250	160

Swivel castors with wheel brakes and foot guards for your safety.



# Small order-picking trolleys



## Small order-picking trolleys

Welded steel construction; Open shelves or of wood-based board, surface finish beech, edge 10 mm high; Trolley powder-coated RAL 5010 gentian blue; permanent surface protection; impact- and scratch-resistant; Grey non-marking thermoplastic rubber tyres with precision deep-groove ball bearings; thread and foot guard; 2 **EasySTOP** swivel castors and 2 fixed castors; Shelf heights: 210, 675, 1140 mm; Carrying capacity, upper and middle shelves: 50 kg

### Small order-picking trolley, 3 wooden shelves

REF	Dimension					Loading surface	Weight	Load cap.	Wheel diam.
	mm								
	a	b	c	d	e				
138TA4028	818	455	1150	612	412	28,0	200	125	

**EasySTOP** swivel castors and foot guards for your safety.



Small order-picking trolley  
REF 138TA4028

**What is EasySTOP and what makes it so special? Information on page 7**

### Small order-picking trolley, 3 plastic crate (600 x 400 x 220 mm, 45 liter)

REF	Dimension					Loading surface	Weight	Load cap.	Wheel diam.
	mm								
	a	b	c	d	e				
138TA4030	818	455	1332	612	412	26,5	200	125	

**EasySTOP** swivel castors and foot guards for your safety.



Small order-picking trolley  
REF 138TA4030

### Small order-picking trolley, 3 open shelves

REF	Dimension					Loading surface	Weight	Load cap.	Wheel diam.
	mm								
	a	b	c	d	e				
138TA4029	818	455	1150	612	412	22,5	200	125	

**EasySTOP** swivel castors and foot guards for your safety.



Small order-picking trolley  
REF 138TA4029

Plastic crate on page 62

### Small order-picking trolley, 3 wooden sloping shelves, tilts to 15° or 30°

REF	Dimension					Loading surface	Weight	Load cap.	Wheel diam.
	mm								
	a	b	c	d	e				
138TA4031	818	455	1160	612	412	30,5	200	125	

**EasySTOP** swivel castors and foot guards for your safety.



Small order-picking trolley  
REF 138TA4031

### Small order-picking trolley, 3 plastic crate (600 x 400 x 220 mm, 45 liter), tilts to 15° or 30°

REF	Dimension					Loading surface	Weight	Load cap.	Wheel diam.
	mm								
	a	b	c	d	e				
138TA4033	818	455	1342	612	412	29,0	200	125	

**EasySTOP** swivel castors and foot guards for your safety.



Small order-picking trolley  
REF 138TA4033

### Small order-picking trolley, 3 open sloping shelves, tiltable, tilts to 15° or 30°

REF	Dimension					Loading surface	Weight	Load cap.	Wheel diam.
	mm								
	a	b	c	d	e				
138TA4032	818	455	1160	612	412	23,5	200	125	

**EasySTOP** swivel castors and foot guards for your safety.



Small order-picking trolley  
REF 138TA4032

# Material stands

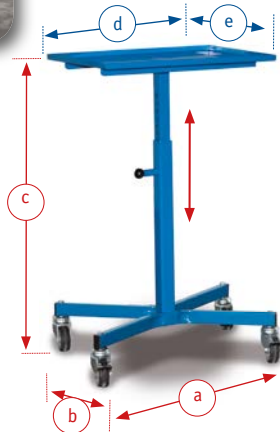

Material stand  
REF 161TA6205



Material stand  
REF 161TA6206



Material stand  
REF 161TA6208



Material stand  
REF 161TA6207



Continuously,  
easy and precise  
adjustment of  
working height  
even if fully loaded.

Material stand  
REF 161TA6439

## Material stands

Welded steel construction; Load surface with 20 mm high edge on one or all sides; height adjustment range 500-770, 720-970 or 750-1100 mm in steps of 25 mm; Secure positioning by spring catch; Powder-coated RAL 5010 gentian blue; permanent surface protection; impact- and scratchresistant; Solid-rubber wheels 75 mm, 4 swivel castors including 2 with wheel brakes.

### Material stand, height adjustment range 720 - 970 mm

REF	Dimension			Loading surface		Weight	Load cap.	Wheel diam.
	a	b	c	d	e			
161TA6205	610	410	720-970	606	406	18,5	150	75

Swivel castors with wheel brakes!

### Material stand, height adjustment range 500 - 770 mm

REF	Dimension			Loading surface		Weight	Load cap.	Wheel diam.
	a	b	c	d	e			
161TA6206	610	410	500-770	606	406	18,0	150	75

Swivel castors with wheel brakes!

### Material stand, height adjustment range 750 - 1100 mm, tilts to 15° and 30°

REF	Dimension			Loading surface		Weight	Load cap.	Wheel diam.
	a	b	c	d	e			
161TA6208	600	410	750-1100	510	408	18,0	150	75

Swivel castors with wheel brakes!

### Material stand, height adjustment range 500 - 770 mm, tilts to 15° and 30°

REF	Dimension			Loading surface		Weight	Load cap.	Wheel diam.
	a	b	c	d	e			
161TA6207	600	410	500-770	510	408	16,5	150	75

Swivel castors with wheel brakes!

## Material stands with hand crank

Welded steel construction; Load surface with edge on one side, 20 mm high; Platform bolted to frame, permitting variable extension with other types of platform; Zero-play adjustable telescopic system, self-locking; continuously adjustable by hand crank; Platform height adjustable even under full load; Powder-coated RAL 5010 gentian blue; permanent surface protection; impact and scratch resistant; Solid-rubber wheels 75 mm, 4 swivel castors including 2 with wheel brakes



Adjustment  
of tolerance  
with a screw



Platform is screwed on the  
basis, therefore variable  
adjustable with other types of  
platform. Tilts to 15° and 30°.

### Material stand with hand crank 655 - 1045 mm, sloping 15° and 30°

REF	Dimension			Loading surface		Weight	Load cap.	Wheel diam.
	a	b	c	d	e			
161TA6439	600	410	655-1045	510	405	22,5	150	75

Swivel castors with wheel brakes!

# Table transporter



## Table transporter

For ergonomic shifting and transport of tables up to a length of ca. 1700 mm; Cuts working time by at least half! For diagonal and length wise transport; Depth of immersion: max. 850 mm under the table; Underclearance of table: min. 635 mm

**Saves min. 50 % work!**



Table support with rubber pads. Guaranteed non-damaging engagement and non-slip transport.



Lift is automatically locked in final position. The table is lowered by operating a release lever on the pushbar.



Pushbar clamp

Swivel castor with thermoplastic tyre. Maintenance-free precision deep-groove ball bearing.



Measurements with pushbar folded approx. 870 x 860 mm (W/H)

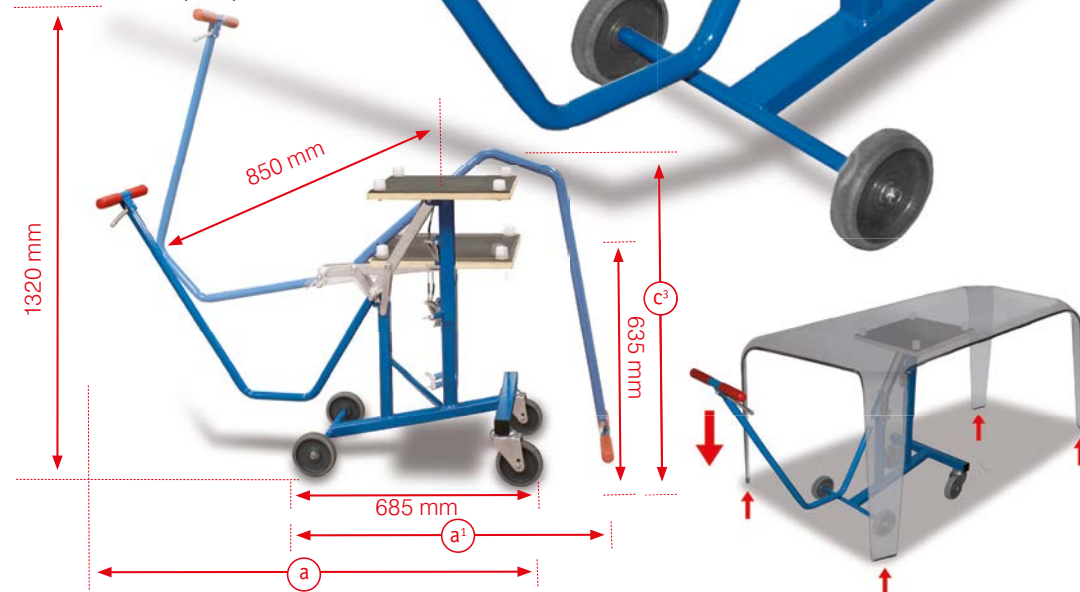

Chair truck page 80

Table transporter  
REF 161TA6663

### Table transporter

REF	Dimensions			Load cap.		Weight	Load cap.	Wheel diam.
	a	b	c	d	e	kg	kg	mm
161TA6663	1200	490	828	375	375	18	100	125
	a <sup>1</sup>	b <sup>2</sup>	c <sup>3</sup>	Measurements with pushbar folded.				
	870	490	860					





# Push-handle dollies

## Push-handle dollies

Welded steel construction; Tubular steel load surface or load surface of woodbased board, surface finish beech; Screw-on handles; Dolly powder-coated RAL 5010 gentian blue; permanent surface protection; impact-resistant and scratch-resistant; Grey non-marking thermoplastic rubber tyres with precision deep-groove ball bearings; thread and foot guard; 1 or 2 swivel castors with wheel brakes and 2 fixed castors

Push-handle dolly  
REF 120TA9924



### Push-handle dolly with tubular steel load surface

REF	Dimension			Loading surface		Weight	Load cap.	Wheel diam.
	mm			mm				
	a	b	c	d	e	kg	kg	mm
120TA9924	874	500	877	603	500	11,5	250	125

Swivel castors with wheel brakes and foot guards for your safety.

Push-handle dolly  
REF 120TA9925



### Push-handle dolly with board load surface

REF	Dimension			Loading surface		Weight	Load cap.	Wheel diam.
	mm			mm				
	a	b	c	d	e	kg	kg	mm
120TA9925	874	500	877	603	500	11,5	250	125

Swivel castors with wheel brakes and foot guards for your safety.

Push-handle dolly  
REF 138TA4014



### Push-handle dolly with tubular steel load surface

REF	Dimension			Loading surface		Weight	Load cap.	Wheel diam.
	mm			mm				
	a	b	c	d	e	kg	kg	mm
138TA4014	784	450	878	567	450	9,0	150	125

Swivel castors with wheel brakes and foot guards for your safety.

Push-handle dolly  
REF 120TA9926



### Push-handle dolly with board load surface

REF	Dimension			Loading surface		Weight	Load cap.	Wheel diam.
	mm			mm				
	a	b	c	d	e	kg	kg	mm
120TA9926	784	450	878	567	450	9,0	150	125

Swivel castors with wheel brakes and foot guards for your safety.



Push-handle dolly  
REF 120TA9927



### optional Push-handle dolly with 2 board load surfaces, heights 185 / 770 mm

REF	Dimension			Loading surface		Weight	Load cap.	Wheel diam.
	mm			mm				
	a	b	c	d	e	kg	kg	mm
120TA9927	891	450	883	603	450	16,0	200	125

Swivel castors with wheel brakes and foot guards for your safety.

Push-handle dolly  
REF 120TA9928



### Push-handle dolly, open

REF	Dimension			Loading surface		Weight	Load cap.	Wheel diam.
	mm			mm				
	a	b	c	d	e	kg	kg	mm
120TA9928	892	420	875	614	414	10,0	250	125

Swivel castors with wheel brakes and foot guards for your safety.

Push-handle dolly  
REF 120TA9929



### Push-handle dolly with plastic crate (600 x 400 x 220 mm, 45 liter)

REF	Dimension			Loading surface		Weight	Load cap.	Wheel diam.
	mm			mm				
	a	b	c	d	e	kg	kg	mm
120TA9929	892	420	875	614	414	12,0	250	125

Swivel castors with wheel brakes and foot guards for your safety.

# System dollies



## System dollies

Welded angle-steel construction; Versions with or without load surface of wood-based board, surface finish beech; For Euro size container 600 x 400 mm; Dolly without load surface for Euro size container 600 x 400 mm; Dolly powder-coated RAL 5010 gentian blue; permanent surface protection; impact- and scratch-resistant; Grey non-marking thermoplastic rubber tyres with precision deep-groove ball bearings; thread and foot guard; 4 swivel castors including 2 with wheel brakes

### Euro dolly

REF	Dimension			Loading surface		Weight	Load cap.	Wheel diam.
	mm			mm				
	a	b	c	d	e			
138TA4007	620	420	195	614	414	8,0	250	125

Swivel castors with wheel brakes and foot guards for your safety.

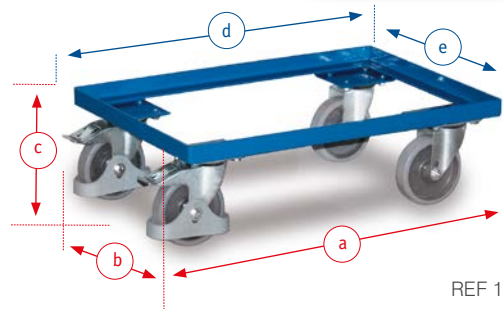

Euro dolly  
REF 138TA4007

### Euro system dolly

REF	Dimension			Loading surface		Weight	Load cap.	Wheel diam.
	mm			mm				
	a	b	c	d	e			
138TA4008	677	416	203	604	410	8,0	250	125

Swivel castors with wheel brakes and foot guards for your safety.



Euro system dolly  
REF 138TA4008

### Euro dolly with wood-based board load surface, edge 10 mm high (not expandable)

REF	Dimension			Loading surface		Weight	Load cap.	Wheel diam.
	mm			mm				
	a	b	c	d	e			
161TA6796	620	420	195	614	414	11,0	250	125

### Euro dolly with wood-based board load surface, edge flush with frame (not expandable)

161TA6795	620	420	195	604	410	11,0	250	125
-----------	-----	-----	-----	-----	-----	------	-----	-----

Swivel castors with wheel brakes and foot guards for your safety.



Euro dolly  
REF 161TA6796

REF 161TA6795

### Accessory:

Tubular pushbar for system dolly Art. No. gsw-410.000.1

### Euro system dolly with load surface of wood-based board, top flush with frame

REF	Dimension			Loading surface		Weight	Load cap.	Wheel diam.
	mm			mm				
	a	b	c	d	e			
138TA4009	677	416	203	604	410	11,0	250	125

### Euro system dolly with wood-based board load surface, top flush with frame

138TA4010	677	416	203	604	410	11,0	250	125
-----------	-----	-----	-----	-----	-----	------	-----	-----

Swivel castors with wheel brakes and foot guards for your safety.



Euro system dolly  
REF 138TA4009

REF 138TA4010

### Euro system dolly with pushbar, base with 10 mm edge

REF	Dimension			Loading surface		Weight	Load cap.	Wheel diam.
	mm			mm				
	a	b	c	d	e			
138TA4011	742	416	969	604	410	13,5	250	125

### Euro system dolly with pushbar, plate flush with frame

161TA6797	742	416	969	604	410	13,5	250	125
-----------	-----	-----	-----	-----	-----	------	-----	-----

Swivel castors with wheel brakes and foot guards for your safety.



Euro system dolly  
REF 138TA4011

REF 161TA6797

ESD version also available, see page 27

### Euro system dolly with 2 load surfaces and 10 mm edge

REF	Dimension			Loading surface		Weight	Load cap.	Wheel diam.
	mm			mm				
	a	b	c	d	e			
138TA4012	677	416	637	604	410	20,0	250	125

### Euro system dolly with 2 load surfaces

138TA4013	677	416	637	604	410	20,0	250	125
-----------	-----	-----	-----	-----	-----	------	-----	-----

Swivel castors with wheel brakes and foot guards for your safety.



Euro system dolly  
REF 138TA4012

Euro system dolly  
REF 138TA4013

# Crate dollies



Crate dolly  
REF 138TA4015

## Crate dollies

Welded angle-steel construction; Dolly powder-coated RAL 5010 gentian blue; permanent surface protection; impact-and scratch-resistant; Grey non-marking thermoplastic rubber tyres with precision deep-groove ball bearings; thread and foot guard; 4 swivel castors including 2 with wheel brakes

### Crate dolly with open frame

REF	Dimension			Loading surface		Weight kg	Load cap. kg	Wheel diam. mm
	a	b	c	d	e			
138TA4015	500	500	169	500	500	9,0	400	125

Swivel castors with wheel brakes and foot guards for your safety.



Crate dolly  
REF 138TA4016

### Crate dolly with board load surface

REF	Dimension			Loading surface		Weight kg	Load cap. kg	Wheel diam. mm
	a	b	c	d	e			
138TA4016	500	500	185	500	500	12,0	400	125

Swivel castors with wheel brakes and foot guards for your safety.



Crate dolly  
REF 138TA4017

### Crate dolly with ribbed rubber covering

REF	Dimension			Loading surface		Weight kg	Load cap. kg	Wheel diam. mm
	a	b	c	d	e			
138TA4017	500	500	185	500	500	12,5	400	125

Swivel castors with wheel brakes and foot guards for your safety.



Crate dolly  
REF 138TA4018

### Crate dolly with diamond-tread load surface

REF	Dimension			Loading surface		Weight kg	Load cap. kg	Wheel diam. mm
	a	b	c	d	e			
138TA4018	500	500	169	500	500	13,0	400	125

Swivel castors with wheel brakes and foot guards for your safety.



# Long-goods trolleys / dolly



## Long-goods trolley

Welded angled-steel construction; with push-fit tubular steel stanchions; 2 material recesses; centre free for loading by crane or stacker truck; Powder-coated RAL 5010 gentian blue; permanent surface protection; impact-and scratch-resistant; 2 centre wheels of elastic solid rubber or polyurethane wheels 360 x 60 mm; plus 1 swivel castor at each end with wheel brake, diameter 200 x 50 mm; loading height 420 mm; useful height of stanchions 600 mm; total length 720 mm; clear width 600 mm

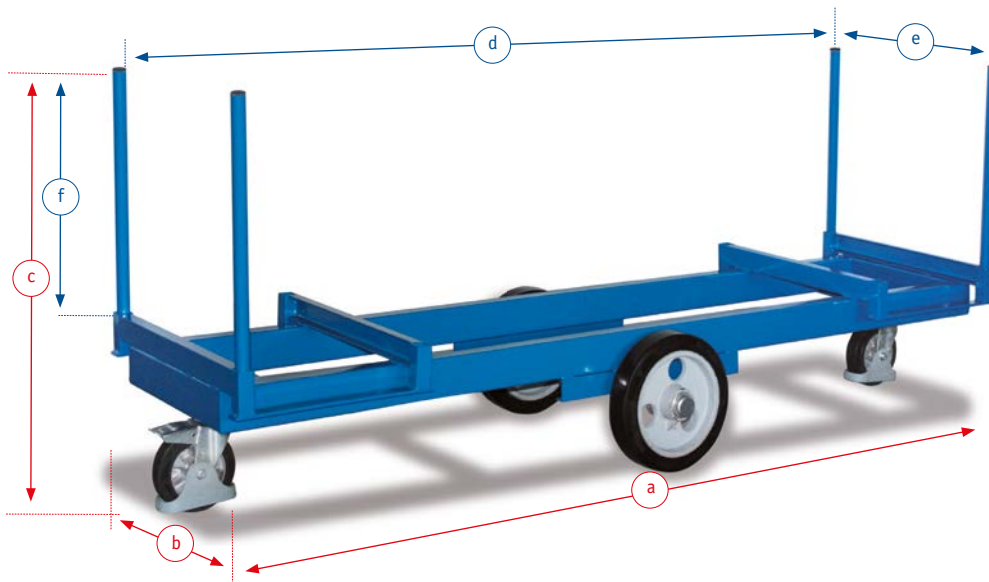

Long-goods trolley  
REF 138TA3983

Long-goods trolley with 4 stanchions. Total length 720 mm, clear width 600 mm

REF		Dimension			Loading surface		Fill height	Weight	Load cap.	Wheel diam.
		a	b	c	d	e	f			
138TA3983	ER	2500	720	1020	2500	600	600	115,0	2000	350/200
138TA3984	PO	2500	720	1020	2500	600	600	123,0	3000	350/200

Swivel castors with wheel brakes and foot guards for your safety.

ER = Elastic-solid-rubber wheels, PO = Polyurethane wheels



Elastic-solid-rubber  
wheels



Polyurethane  
wheels

Info page 8

## Long-goods dolly

Welded angle-steel construction; with push-fit tubular steel stanchions, length 500 mm; waterproof bonded plywood platform, surface finish screen printed; loading height 330 mm; Powder-coated RAL 5010 gentian blue; permanent surface protection; impact- and scratch-resistant; Elastic solid-rubber wheels 200 x 50 mm; ballbearing hubs, 4 swivel castors including 2 with wheel brake and foot guard

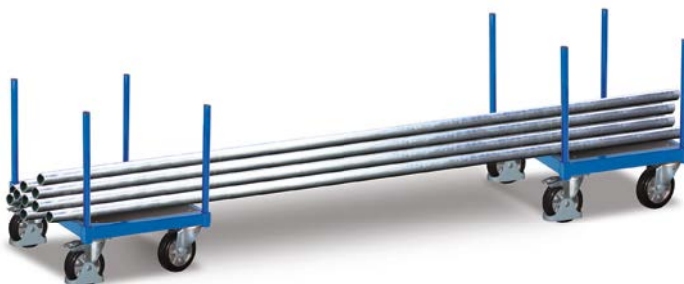

Long-goods (1pc.) dolly with waterproof platform and 4 stanchions, usable height 500 mm

REF	Dimension			Loading surface		Fill height	Weight	Load cap.	Wheel diam.
	a	b	c	d	e	f			
138TA3985	700	700	739	627	627	410	50	1200	200 x 50

Swivel castors with wheel brakes and foot guards for your safety.

Long-goods dolly  
REF 138TA3985

VARIOfit®



Trucks



Tyrehandling

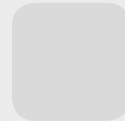

# Tyre trucks

## Tyre trucks

Tyre truck for tyre diameter 540 - 820 mm; with wheel protection guards; Makes it easy to pick up, transport and set down whole stacks of tyres; Pneumatic or solid-rubber tyres on pressed-steel wheels with plastic wheel cap; Rolls very easily and quietly thanks to maintenance-free precision deep-groove ball bearings with dust seals. Galvanised versions of all tyre trucks are also available

### Tyre trucks high

REF		Dimension			Weight	Load cap.	Wheel diam.
		mm					
		a	b	c	kg	kg	mm
137TA1820	P	745	760	1600	22,0	200	260
137TA1821	SR	745	760	1600	25,5	200	250

**Steel-rim wheels with precision deep-groove ball bearings**  
P = pneumatic tyres, SR = solid-rubber tyres

### Tyre trucks low

REF		Dimension			Weight	Load cap.	Wheel diam.
		mm					
		a	b	c	kg	kg	mm
161TA6427	P	745	610	1164	19,0	200	260
161TA6428	SR	745	610	1164	23,0	200	250

**Steel-rim wheels with precision deep-groove ball bearings**  
P = pneumatic tyres, SR = solid-rubber tyres

- Large pushbar with soft plastic grip cover for easy manoeuvring
- Lever system with gas pressure springs for stay-open and clamping functions
- Robust pickup arms
- All parts easy to fit
- Centre of gravity is very close to the axle, thus ensuring easy tilting
- 1 non-slip pedal each on axle and supporting wheel (only on trucks with supporting wheels)

### Tyre trucks with supporting wheel

REF		Dimension			Weight	Load cap.	Wheel diam.
		mm					
		a	b	c	kg	kg	mm
161TA6655	P	745	760	1600	26,0	200	260
161TA6656	SR	745	760	1600	30,0	200	250

**Steel-rim wheels with precision deep-groove ball bearings**  
P = pneumatic tyres, SR = solid-rubber tyres

### Tyre trucks galvanised

REF		Dimension			Weight	Load cap.	Wheel diam.
		mm					
		a	b	c	kg	kg	mm
137TA1824	P	745	760	1600	22,0	200	260
137TA1825	SR	745	760	1600	26,0	200	250
161TA6429	P	745	610	1164	20,0	200	260
161TA6430	SR	745	610	1164	24,0	200	250

**Steel-rim wheels with precision deep-groove ball bearings**  
P = pneumatic tyres, SR = solid-rubber tyres

1 non-slip pedal each on axle and supporting wheel (only on trucks with supporting wheels)

- 1. step = 1300 mm
- 2. step = 1600 mm
- 3. step = 1750 mm
- 4. step = 1900 mm



### Tyre trucks with telescopic extension for up to 8 wheels (245 mm wide)

REF		Dimension			Weight	Load cap.	Wheel diam.
		mm					
		a	b	c	kg	kg	mm
161TA6657	P	745	760	1300 - 1900	27,0	200	260
161TA6658	SR	745	760	1300 - 1900	31,0	200	250

**Steel-rim wheels with precision deep-groove ball bearings**  
P = pneumatic tyres, SR = solid-rubber tyres



Tyre truck  
REF 137TA1820



for all trucks



Info Page 11, 77

Tyre truck low  
REF 161TA6427



Tyre truck  
REF 161TA6655



Tyre truck  
REF 161TA6429

Tyre truck  
REF 137TA1824



Tyre truck  
REF 161TA6657





# Tyre rack / Tyre trolley

the base . . .

## Tyre rack / Tyre trolley

Welded tubular steel; Galvanised connecting tubes; boltmounted; hence variable width – prices on request; Rack is suitable for wheel diameters of 540 - 820 mm; rack powder-coated RAL 5010 gentian blue; permanent surface protection; impact- and scratch-resistant; also available as galvanised version



Tyre trolley the base  
REF 161TA6679



Tyre rack the base  
REF 161TA6680

### Tyre racks and tyre trolley, the base (4x up to 275 mm wheel per shelf)

REF	Dimension			Loading surface		Weight kg	Load cap. kg	Wheel diam. mm
	a	b	c	d	e			
161TA6679	1350	790	1430	1130	646	33,5	300	125
161TA6680	1350	790	1360	1130	646	31,0	300	/

Swivel castors with wheel brakes and foot guards for your safety.

Tyre magazine on 9 x 12 m  
48 Tyretrolleys

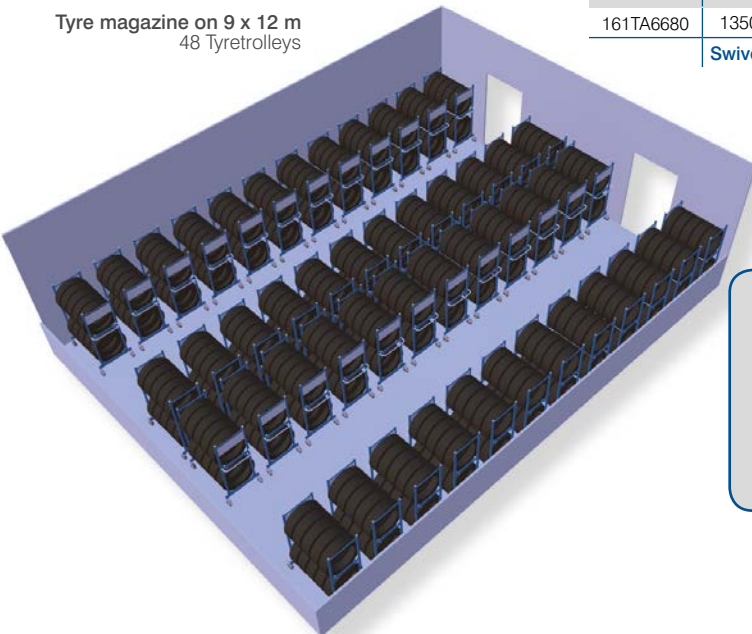

#### optional:

- Possibility of mounting 4 connecting tubes between 2 tyre racks (make 3 out of 2)
- Level tubes for useful length = 940 mm (4x up to 275 mm wheel per shelf)
- Level tubes for useful length = 1880 mm (8x up to 275 mm wheel per shelf)

# Additional Articles

## Shelf for Tyre rack and Tyre trolley

REF	Dimension			Loading surface		Weight	Load cap.
	a	b	c	d	e		
161TA6629	1225	646	704	1130	646	15,0	250



Shelf  
REF 161TA6629



**VARIOfit**  
The perfect form  
of transport

## Distance pieces

Putting the galvanized distance pieces in the tubes of the tyre truck/rack you can store wheels with diameter up to 820 mm instead of 650 mm in the second level even if a further level is installed; To adjust the height 4 pieces are needed

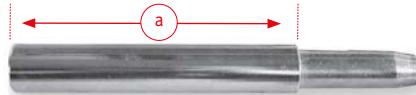

### Distance pieces for tyre truck and tyre rack

REF	Piece	Dimension	Weight
		mm	
161TA6720	1	a	0,4



Distance pieces  
REF 161TA6720

## Push-and-pull bar, movable

REF	Dimension	Weight
	mm	
161TA6715	370	1,5



Push-and-pull bar  
REF 161TA6715

## Plastic clips for tyre truck / rack, set of 8

REF	Dimension		Weight
	mm	Piece	
161TA6716	∅	c	0,5
	33,7	4	
		2	

670 mm for lower pipes of the tyre truck  
300 mm for right pipes of the tyre truck  
270 mm for left pipes of the tyre truck (clipboard)



Plastic clips  
REF 161TA6716

## Plastic clips for Shelf / rack, set of 8

REF	Dimension		Weight
	mm	Piece	
161TA6717	∅	c	0,3
	33,7	4	
		4	

275 mm for pipes of the upper level  
260 mm for pipes of the lower level



Plastic clips  
REF 161TA6717

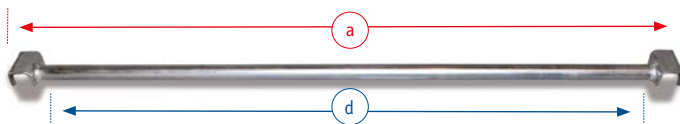

## Extension tube for joining two tyre trolley / tyre racks

REF	Dimension			Weight
	mm	Piece	mm	
161TA6719	∅	a	d	1,5
	26,9	1	1220	

2 pieces extension tubes are required to adjust a further level



Extension tube  
REF 161TA6719

## Feet for tyre stand

REF	Dimension	Load cap.	Weight
	mm		
161TA6718	c	300	0,3



Feet for tyre stand  
REF 161TA6718



# Aluminium and tubular-steel trucks with **puncture-proof** wheels

## Puncture-proof wheels

Aluminium or tubular-steel truck with puncture-proof tyres of heavy-duty cushion rubber, a more comfortable and more profitable alternative to pneumatic tyres. The puncture-proof tyres cushion shocks, absorb vibrations and have excellent directional stability. No more tedious checking of tyre pressures, no worries about nails, glass or kerbstones. On pressed-steel wheels with precision deep-groove ball bearings and wheel cap, they are the ideal tyres for heavy loads and day-to-day use. Lasting up to 5 times longer, they offer greater cost-effectiveness combined with greater operational reliability.

## Tubular-steel truck

REF	Dimension			Toe plate		Weight	Load cap.	Wheel diam.
	mm			mm				
	a	b	c	d	e			
161TA6378	570	605	1305	320	250	19,0	250	260×85

Steel-rim wheels with precision deep-groove ball bearings



Tubular-steel truck  
REF 161TA6378



## Safety handles

using improved materials; their flexibility reduces the risk of breakage and ensures optimum user safety



Puncture-proof wheels are available for all trucks identified by this button.

REF
161TA6652



## Precision deep-groove ball bearings

sealed, maintenance-free precision deep-groove ball bearings. Guaranteed easy running when loaded, even on sloping or rough surfaces



## Plastic skids

Specially developed by VARIOfit®, provide optimum safety. They continue past the bend in the tube to ensure there is no chance of catching or jamming

## Aluminium truck

REF	Dimension			Toe plate		Weight	Load cap.	Wheel diam.
	mm			mm				
	a	b	c	d	e			
161TA6379	570	605	1305	320	250	12,5	200	260×85

Steel-rim wheels with precision deep-groove ball bearings

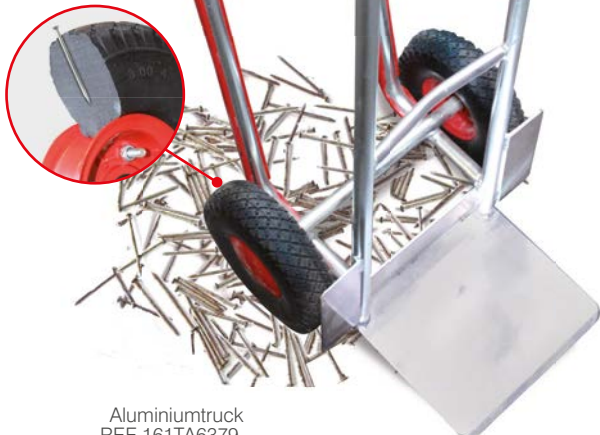

Aluminium truck  
REF 161TA6379



# Tubular-steel trucks



## Tubular-steel trucks

Welded steel construction; with safety handles; Toe of sheet steel; plastic skids are replaceable and mounted completely on the tube; Powder-coated RAL 5010 gentian blue; permanent surface protection; impact- and scratch-resistant; Pneumatic or solid-rubber tyres on steel wheels with precision deep-groove ball bearings and plastic wheel cap

### Tubular-steel trucks

REF		Dimension			Toe plate		Weight	Load cap.	Wheel diam.
		mm			mm				
		a	b	c	d	e			
137TA1766	P	614	455	1100	400	150	14,0	250	260×85
137TA1778	SR	614	455	1100	400	150	17,5	250	250×60

**Steel-rim wheels with precision deep-groove ball bearings**  
P = pneumatic tyres, SR = solid-rubber tyres



Tubular-steel truck  
REF 137TA1778

Tubular-steel truck  
REF 137TA1766

### Tubular-steel trucks

REF		Dimension			Toe plate		Weight	Load cap.	Wheel diam.
		mm			mm				
		a	b	c	d	e			
137TA1765	P	570	531	1100	320	250	13,0	200	260×85
137TA1777	SR	570	531	1100	320	250	17,0	200	250×60

**Steel-rim wheels with precision deep-groove ball bearings**  
P = pneumatic tyres, SR = solid-rubber tyres



Tubular-steel truck  
REF 137TA1765

### Tubular-steel trucks with support wheel

REF		Dimension			Toe plate		Weight	Load cap.	Wheel diam.
		mm			mm				
		a	b	c	d	e			
161TA6790	P	570	586	1305	320	250	21,5	250	260×85
161TA6791	SR	570	586	1305	320	250	24,5	250	250×60

### Tubular-steel trucks

161TA6322	P	570	586	1305	320	250	17,0	250	260×85
137TA1779	SR	570	586	1305	320	250	21,0	250	250×60

**Steel-rim wheels with precision deep-groove ball bearings**  
P = pneumatic tyres, SR = solid-rubber tyres



Tubular-steel truck  
REF 161TA6322

Tubular-steel truck  
REF 161TA6790



Tubular-steel truck  
REF 137TA1768

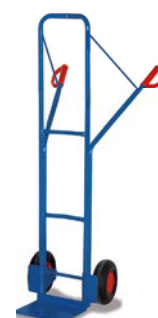

Tubular-steel truck  
REF 137TA1769

### Tubular-steel trucks with plastic skids

REF		Dimension			Toe plate		Weight	Load cap.	Wheel diam.
		mm			mm				
		a	b	c	d	e			
137TA1768	P	570	605	1305	320	250	18,0	250	260×85
137TA1780	SR	570	605	1305	320	250	22,0	250	250×60

**Steel-rim wheels with precision deep-groove ball bearings**  
P = pneumatic tyres, SR = solid-rubber tyres

### Tubular-steel trucks

REF		Dimension			Toe plate		Weight	Load cap.	Wheel diam.
		mm			mm				
		a	b	c	d	e			
137TA1769	P	550	738	1600	300	260	19,5	250	260×85
137TA1781	SR	550	738	1600	300	260	23,5	250	250×60

**Steel-rim wheels with precision deep-groove ball bearings**  
P = pneumatic tyres, SR = solid-rubber tyres

VARIOfit  
The perfect form  
of transport



aluminium versions

# Tubular-steel trucks



Tubular-steel truck  
REF 137TA1770



Tubular-steel truck  
REF 161TA6653



Tubular-steel truck  
REF 137TA1771



Tubular-steel truck  
REF 137TA1772



Tubular-steel truck  
REF 137TA1773

For additional carrying bars for all trucks on pages 76 to 84, see page 84

## Tubular-steel trucks with large toe

REF		Dimension			Toe plate		Weight kg	Load cap. kg	Wheel diam. mm
		mm			mm				
		a	b	c	d	e			
137TA1770	P	685	600	1110	480	300	18,0	250	260×85
137TA1782	SR	685	600	1110	480	300	22,0	250	250×60

Steel-rim wheels with precision deep-groove ball bearings

P = pneumatic tyres, SR = solid-rubber tyres

## Tubular-steel trucks with large toe

REF		Dimension			Toe plate		Weight kg	Load cap. kg	Wheel diam. mm
		mm			mm				
		a	b	c	d	e			
137TA1771	P	685	702	1185	480	300	21,5	250	260×85
137TA1783	SR	685	702	1185	480	300	25,0	250	250×60
161TA6653	P	685	552	1185	480	147	21,0	250	260×85
161TA6654	SR	685	552	1185	480	147	24,5	250	250×60

Steel-rim wheels with precision deep-groove ball bearings

P = pneumatic tyres, SR = solid-rubber tyres



## Safety handles

using improved materials; their flexibility reduces the risk of breakage and ensures optimum user safety

## Tubular-steel trucks with large toe

REF		Dimension			Toe plate		Weight kg	Load cap. kg	Wheel diam. mm
		mm			mm				
		a	b	c	d	e			
137TA1772	P	570	636	1305	480	300	19,5	250	260×85
137TA1784	SR	570	636	1305	480	300	23,5	250	250×60

Steel-rim wheels with precision deep-groove ball bearings

P = pneumatic tyres, SR = solid-rubber tyres



## Pastic skids

Specially developed by VARIOfit® provide optimum safety. They continue past the bend in the tube to ensure there is no chance of catching or jamming on steps.

## Tubular-steel trucks with large toe and plastic skids

REF		Dimension			Toe plate		Weight kg	Load cap. kg	Wheel diam. mm
		mm			mm				
		a	b	c	d	e			
137TA1773	P	570	657	1305	480	300	19,5	250	260×85
137TA1785	SR	570	657	1305	480	300	23,5	250	250×60

Steel-rim wheels with precision deep-groove ball bearings

P = pneumatic tyres, SR = solid-rubber tyres

# Aluminium trucks



## Aluminium trucks

Welded aluminium construction; with aluminium toe; safety handles; plastic skids are replaceable and mounted completely on the tube; Pneumatic or solid-rubber tyres on steel wheels with ball bearings and plastic wheel cap

### Aluminium trucks

REF		Dimension			Toe plate		Weight	Load cap.	Wheel diam.
		mm			mm				
		a	b	c	d	e			
137TA1790	P	570	531	1100	320	250	8,5	150	260×85
137TA1791	SR	570	531	1100	320	250	12,5	150	250×60

**Steel-rim wheels with precision deep-groove ball bearings**

P = pneumatic tyres, SR = solid-rubber tyres



Aluminium truck  
REF 137TA1790

**Pneumatic tyres with groove profile for all trucks**

- moves 30% easier
- groove profile absorbs less dirt
- low noise moving profile



### Aluminium trucks

REF		Dimension			Toe plate		Weight	Load cap.	Wheel diam.
		mm			mm				
		a	b	c	d	e			
137TA1792	P	570	586	1305	320	250	11,0	200	260×85
137TA1793	SR	570	586	1305	320	250	14,5	200	250×60

**Steel-rim wheels with precision deep-groove ball bearings**

P = pneumatic tyres, SR = solid-rubber tyres



Aluminium truck  
REF 137TA1792



### Aluminium trucks with plastic skids

REF		Dimension			Toe plate		Weight	Load cap.	Wheel diam.
		mm			mm				
		a	b	c	d	e			
137TA1794	P	570	605	1305	320	250	11,5	200	260×85
137TA1795	SR	570	605	1305	320	250	14,0	200	250×60

**Steel-rim wheels with precision deep-groove ball bearings**

P = pneumatic tyres, SR = solid-rubber tyres



Aluminium truck  
REF 137TA1794





# Aluminium trucks



Aluminium truck  
REF 137TA1796

## Aluminium trucks

Welded aluminium construction; with aluminium toe; safety handles; plastic skids are replaceable and mounted completely on the tube; Pneumatic or solid-rubber tyres on steel wheels with ball bearings and plastic wheel cap

### Aluminium trucks with large toe plate

REF		Dimension			Toe plate		Weight	Load cap.	Wheel diam.
		mm			mm				
		a	b	c	d	e	kg	kg	mm
137TA1796	P	570	636	1305	480	300	11,5	200	260×85
137TA1797	SR	570	636	1305	480	300	15,5	200	250×60

Steel-rim wheels with precision deep-groove ball bearings

P = pneumatic tyres, SR = solid-rubber tyres



Aluminium truck  
REF 137TA1800



## Safety handles

using improved materials; their flexibility reduces the risk of breakage and ensures optimum user safety

### Aluminium trucks with large toe plate

REF		Dimension			Toe plate		Weight	Load cap.	Wheel diam.
		mm			mm				
		a	b	c	d	e	kg	kg	mm
137TA1800	P	685	600	1110	480	300	10,5	200	260×85
137TA1801	SR	685	600	1110	480	300	14,5	200	250×60

Steel-rim wheels with precision deep-groove ball bearings

P = pneumatic tyres, SR = solid-rubber tyres



Aluminium truck  
REF 137TA1798



## Pastic skids

Specially developed by VARIOfit® provide optimum safety. They continue past the bend in the tube to ensure there is no chance of catching or jamming on steps.

### Aluminium trucks with large toe plate and plastic skids

REF		Dimension			Toe plate		Weight	Load cap.	Wheel diam.
		mm			mm				
		a	b	c	d	e	kg	kg	mm
137TA1798	P	570	657	1305	480	300	12,5	200	260×85
137TA1799	SR	570	657	1305	480	300	16,5	200	250×60

Steel-rim wheels with precision deep-groove ball bearings

P = pneumatic tyres, SR = solid-rubber tyres

# Aluminium and tubular-steel trucks with folding toe



## Aluminium and tubular-steel trucks with folding toe

Robust welded construction; with safety handles; Folding toe; plastic skids are replaceable and mounted completely on the tube; Powder-coated RAL 5010 gentian blue; permanent surface protection; impact- and scratch-resistant; or as aluminium version; Pneumatic or solid-rubber tyres on pressed-steel wheels with ball bearings and plastic wheel cap

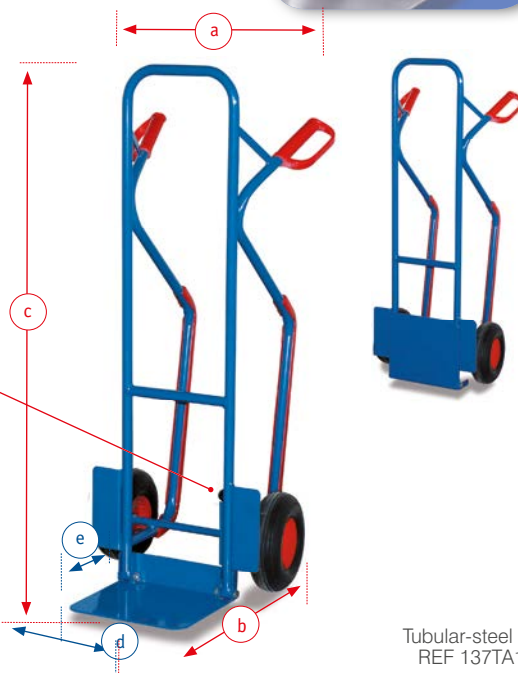

Tubular-steel truck  
REF 137TA1776

### Tubular-steel trucks with folding toe plate

REF		Dimension			Toe plate		Weight	Load cap.	Wheel diam.
		mm			mm				
		a	b	c	d	e	kg	kg	mm
137TA1776	P	570	610	1300	320	255	18,5	200	260×85
137TA1788	SR	570	610	1300	320	255	22,0	200	250×60

Steel-rim wheels with precision deep-groove ball bearings

P = pneumatic tyres, SR = solid-rubber tyres

### Tubular-steel trucks with folding toe plate

REF		Dimension			Toe plate		Weight	Load cap.	Wheel diam.
		mm			mm				
		a	b	c	d	e	kg	kg	mm
137TA1775	P	570	525	1300	320	255	18,0	250	260×85
137TA1787	SR	570	525	1300	320	255	21,5	250	250×60

Steel-rim wheels with precision deep-groove ball bearings

P = pneumatic tyres, SR = solid-rubber tyres



Tubular-steel truck  
REF 137TA1775



### Aluminium trucks with folding toe plate with plastic skids

REF		Dimension			Toe plate		Weight	Load cap.	Wheel diam.
		mm			mm				
		a	b	c	d	e	kg	kg	mm
137TA1802	P	570	640	1305	380	280	13,5	200	260×85
137TA1803	SR	570	640	1305	380	280	17,0	200	250×60

Steel-rim wheels with precision deep-groove ball bearings

P = pneumatic tyres, SR = solid-rubber tyres



Aluminium truck  
REF 137TA1802



# Chair trucks / chair support / wide tubular-steel trucks

## Chair trucks

chair support with antislip covering; removable; with continuous height adjustment; length: 500 mm



Porte-table Page 65



## Chair trucks

REF		Dimension			Toe plate		Weight	Load cap.	Wheel diam.
		mm			mm				
		a	b	c	d	e	kg	kg	mm
137TA1805	P	570	540	1305	320	250	19,5	250	260×85
137TA1806	SR	570	540	1305	320	250	23,5	250	250×60

## Aluminium Chair trucks

161TA6768	P	570	540	1305	320	250	11,5	250	260×85
161TA6769	SR	570	540	1305	320	250	15,5	250	250×60

Steel-rim wheels with precision deep-groove ball bearings  
P = pneumatic tyres, SR = solid-rubber tyres



Aluminium Chair truck  
REF 161TA6768  
Chair truck  
REF 137TA1805



Furniture truck  
REF 161TA6396

Furniture truck  
REF 161TA6425



## Anti-slip cover:

The anti-slip cover prevents the loaded goods from slipping off the toe.



## Soft tube cover:

The soft tube cover protects the goods from minor damage.

## Furniture trucks

REF		Dimension			Toe plate		Weight	Load cap.	Wheel diam.
		mm			mm				
		a	b	c	d	e	kg	kg	mm
161TA6425	P	570	636	1400	360	330	18,0	250	260×85
161TA6426	SR	570	636	1400	360	330	21,5	250	250×60

## Aluminium versions

161TA6395	P	570	636	1400	360	330	8,5	150	260×85
161TA6396	SR	570	636	1400	360	330	12,5	150	250×60

Steel-rim wheels with precision deep-groove ball bearings  
P = pneumatic tyres, SR = solid-rubber tyres



Aluminium truck  
REF 137TA1774



## Aluminium trucks with folding toe plate

REF		Dimension			Toe plate		Weight	Load cap.	Wheel diam.
		mm			mm				
		a	b	c	d	e	kg	kg	mm
137TA1774	P	570	570	1300	480	300	20,5	250	260×85
137TA1786	SR	570	570	1300	480	300	25,0	250	250×60

Steel-rim wheels with precision deep-groove ball bearings  
P = pneumatic tyres, SR = solid-rubber tyres



# Stair-climber trucks



## Stair-climber trucks

Robust welded construction; with safety handles; Powder-coated RAL 5010 gentian blue; permanent surface protection; impact- and scratch-resistant; Available with 2 three-arm or five-arm star wheels; pneumatic or solid-rubber tyres on pressed-steel wheels with ball bearings and plastic wheel caps

### Stair-climber truck with 2 five-arm star wheels (TR) / with large toe plate

REF		Dimension			Toe plate		Weight	Load cap.	Wheel diam.
		mm			mm				
		a	b	c	d	e	kg	kg	mm
161TA6261	P	570	721	1310	480	300	28,5	200	260×85
161TA6262	P	570	721	1310	300	250	26,0	200	260×85

P = pneumatic tyres, TR = Thermoplastic rubber tyres



Stair-climber truck with large toe plate  
REF 161TA6261

Stair-climber truck  
REF 161TA6262

### Stair-climber truck with 2 five-arm star wheels (TR)

REF		Dimension			Toe plate		Weight	Load cap.	Wheel diam.
		mm			mm				
		a	b	c	d	e	kg	kg	mm
137TA1807	P	570	675	1305	300	260	27,5	200	260×85

P = pneumatic tyres, TR = Thermoplastic rubber tyres



Info page 11, 77

Stair-climber truck  
REF 137TA1807



Stair-climber truck with large toe plate  
REF 161TA6320

Stair-climber truck  
REF 129TA5638

### Stair-climber trucks with 2 three-arm star wheels / large toe plate

REF		Dimension			Toe plate		Weight	Load cap.	Wheel diam.
		mm			mm				
		a	b	c	d	e	kg	kg	mm
129TA5638	TR	570	626	1310	320	250	22,5	200	160×40
161TA6320	TR	570	676	1310	480	300	23,5	200	160×40

TR = Thermoplastic rubber tyres

### Stair-climber truck with 2 three-arm star wheels

REF		Dimension			Toe plate		Weight	Load cap.	Wheel diam.
		mm			mm				
		a	b	c	d	e	kg	kg	mm
129TA5647	TR	570	631	1305	300	260	22,5	200	160×40

TR = Thermoplastic rubber tyres



Stair-climber truck  
REF 129TA5647



# Aluminium stair-climber trucks



Aluminium stair-climber truck with large toe plate  
REF 161TA6215

Aluminium stair-climber truck  
REF 161TA6214

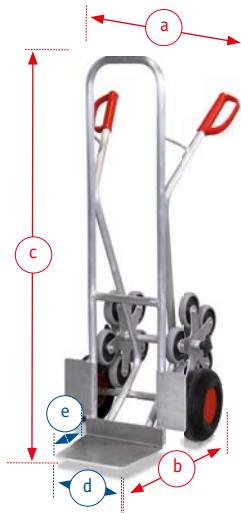

## Aluminium stair-climber trucks

Welded aluminium construction; with aluminium toe; safety handles; Very light and easy to manoeuvre; Available with 2 three-arm or five-arm star wheels; pneumatic or solid-rubber tyres on pressed-steel wheels with ball bearings and plastic wheel caps

### Aluminium stair-climber trucks with 2 five-arm star wheels (TR) / with large toe plate

REF		Dimension			Toe plate		Weight	Load cap.	Wheel diam.
		mm			mm				
		a	b	c	d	e	kg	kg	mm
161TA6215	P	570	721	1310	480	300	16,0	200	260×85
161TA6214	P	570	671	1310	300	250	15,0	200	260×85

P = pneumatic tyres, TR = Thermoplastic rubber tyres



Aluminium stair-climber truck  
REF 137TA1808

### Aluminium stair-climber truck with 2 five-arm star wheels (TR)

REF		Dimension			Toe plate		Weight	Load cap.	Wheel diam.
		mm			mm				
		a	b	c	d	e	kg	kg	mm
137TA1808	P	570	675	1305	300	260	15,5	200	260×85

P = pneumatic tyres, TR = Thermoplastic rubber tyres



Aluminium stair-climber truck with large toe plate  
REF 161TA6216



Aluminium stair-climber truck  
REF 127TA1049

### Aluminium stair-climber trucks with 2 three-arm star wheels / large toe plate

REF		Dimension			Toe plate		Weight	Load cap.	Wheel diam.
		mm			mm				
		a	b	c	d	e	kg	kg	mm
161TA6216	TR	570	676	1310	480	300	13,5	200	160×40
127TA1049	TR	570	626	1310	320	250	12,5	200	160×40

TR = Thermoplastic rubber tyres



Aluminium stair-climber truck  
REF 138TA8165

### Aluminium stair-climber trucks with 2 three-arm star wheels

REF		Dimension			Toe plate		Weight	Load cap.	Wheel diam.
		mm			mm				
		a	b	c	d	e	kg	kg	mm
138TA8165	TR	570	631	1305	300	260	12,5	200	160×40

TR = Thermoplastic rubber tyres

# Tubular-steel trucks



## Tubular-steel trucks

Robust welded construction; with safety handles; Toe of sheet steel; Powder-coated RAL 5010 gentian blue; permanent surface protection; impact- and scratch-resistant; Pneumatic or solid-rubber tyres on pressed-steel wheels with ball bearings and plastic wheel cap

### Tubular-steel trucks

REF		Dimension			Toe plate		Weight	Load cap.	Wheel diam.
		mm			mm				
		a	b	c	d	e	kg	kg	mm
161TA6250	SR	500	500	1100	400	110	15,5	200	250×60
161TA6251	P	500	500	1100	400	110	13,0	200	260×85

P = pneumatic tyres, SR = solid-rubber tyres

### Tubular-steel trucks

REF		Dimension			Toe plate		Weight	Load cap.	Wheel diam.
		mm			mm				
		a	b	c	d	e	kg	kg	mm
161TA6252	SR	600	510	1150	450	120	16,0	250	250×60
161TA6253	P	600	510	1150	450	120	13,5	250	260×85

P = pneumatic tyres, SR = solid-rubber tyres

### Tubular-steel trucks

REF		Dimension			Toe plate		Weight	Load cap.	Wheel diam.
		mm			mm				
		a	b	c	d	e	kg	kg	mm
161TA6254	SR	600	530	1150	450	120	18,5	250	250×60
161TA6255	P	600	530	1150	450	120	16,0	250	260×85

P = pneumatic tyres, SR = solid-rubber tyres

### Tubular-steel trucks

REF		Dimension			Toe plate		Weight	Load cap.	Wheel diam.
		mm			mm				
		a	b	c	d	e	kg	kg	mm
161TA6258	SR	650	540	1250	450	150	19,5	250	250×60
161TA6259	P	650	540	1250	450	150	17,0	250	260×85

P = pneumatic tyres, SR = solid-rubber tyres



Tubular-steel truck  
REF 161TA6250



Tubular-steel truck  
REF 161TA6251



Tubular-steel truck  
REF 161TA6252



Tubular-steel truck  
REF 161TA6253



Tubular-steel truck  
REF 161TA6254

for all trucks



Info page 11, 77





# Appliance trucks



Appliance truck  
REF 161TA6260



Appliance truck  
REF 161TA6257



Appliance truck  
REF 161TA6256

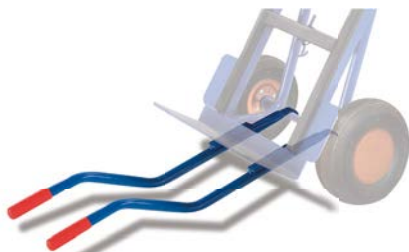

Additional carrying bar  
REF 136TA1011

## Appliance trucks

Robust welded construction; with safety handles; for transporting ovens, refrigerators, washing machines etc.; Toe and bars with hollow rubber profile protect the transported goods and reduced the risk of slipping; Powder-coated RAL 5010 gentian blue; permanent surface protection; impact- and scratch-resistant; Pneumatic tyres on pressed-steel wheels with ball bearing and wheel cap, or with 2 three-arm star wheels for stair-climbing transport; Additional carrying bar available for stair-climbing applications



### Appliance truck

REF		Dimension			Toe plate		Weight	Load cap.	Wheel diam.
		mm			mm				
		a	b	c	d	e	kg	kg	mm
161TA6260	SR	705	575	1450	450	122	32,0	250	250×60

SR = solid-rubber tyres

### Appliance truck with 2 three-arm star wheels

REF		Dimension			Toe plate		Weight	Load cap.	Wheel diam.
		mm			mm				
		a	b	c	d	e	kg	kg	mm
161TA6257	TR	660	520	1150	450	150	21,0	250	160×40

TR = Thermoplastic rubber tyres



### Appliance truck with pneumatic tyres

REF		Dimension			Toe plate		Weight	Load cap.	Wheel diam.
		mm			mm				
		a	b	c	d	e	kg	kg	mm
161TA6256	P	660	440	1150	450	150	17,5	250	260×85

P = pneumatic tyres

For additional carrying bars for all trucks on pages 74 to 84

### Additional carrying bar for stair climbing

REF	Weight	Length	
	kg	mm	
136TA1011	3,0	850	carrying bar

# Steel-cylinder trucks-/ trolley



VARIOfit  
The perfect form  
of transport

## Steel-cylinder trucks

Robust welded construction; with safety handles; for easy transport of steel cylinders with a capacity of 10, 40 or 50 litres; diameter 210 – 250 mm; Cylinder holder with safety chains; Powder-coated RAL 5010 gentian blue, permanent surface protection, impact- and scratch-resistant; Pneumatic or solid-rubber tyres with ball bearings

### Steel-cylinder truck for 2 steel cylinders of 40-50 litres capacity, with filler rod holder

REF		Dimension			Toe plate		Weight	Load cap.	Wheel diam.
		mm			mm				
		a	b	c	d	e			
137TA1809	SR	875	1010	1250	584	250	33,0	200	400×80
137TA1810	P	875	1010	1250	584	250	21,0	200	400×100

P = pneumatic tyres SR = solid-rubber tyres

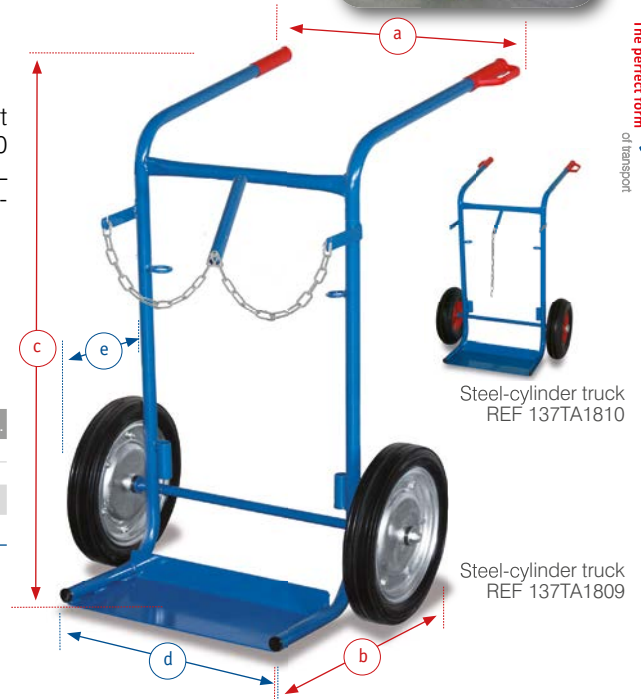

Steel-cylinder truck  
REF 137TA1810

Steel-cylinder truck  
REF 137TA1809

### Steel-cylinder truck for 2 steel cylinders of 40-50 litres capacity, with additional support roller and filler rod holder

REF		Dimension			Toe plate		Weight	Load cap.	Wheel diam.
		mm			mm				
		a	b	c	d	e			
137TA1811	SR	857	1030	1250	584	250	49,0	200	400×80
137TA1812	P	857	1030	1250	584	250	37,0	200	400×100

P = pneumatic tyres SR = solid-rubber tyres



Steel-cylinder truck  
REF 137TA1811

### Steel-cylinder truck for 2 steel cylinders of 10 litres capacity

REF		Dimension			Toe plate		Weight	Load cap.	Wheel diam.
		mm			mm				
		a	b	c	d	e			
137TA1813	SR	620	365	1045	465	210	10,5	50	200×50

SR = solid-rubber tyres



Steel-cylinder truck  
REF 137TA1813

## Steel-cylinder trolley

Welded steel construction; Push bar vertical or horizontal with dead man's brake; 2 shelves with hole cutouts ø 160 mm; Load surface of waterproof bonded plywood, surface finish screen printed, antislip; for 24 steel cylinders; Load capacity 80 kg; trolley powder-coated RAL 5010 gentian blue; permanent surface protection; impact- and scratch-resistant; Grey non-marking thermoplastic rubber tyres with precision deep-groove ball bearings; thread and foot guard; 2 swivel castors with wheel brakes or 2 swivel castors with dead man's brake and 2 fixed castors.

### Steel-cylinder trolley for 24 cylinders,

REF		Dimension			Loading surface		Weight	Load cap.	Wheel diam.
		mm			mm				
		a	b	c	d	e			
161TA6814	TR	1250	760	1000	1000	700	62,0	500	200

### Steel-cylinder trolley for 24 cylinders, with dead man's brake

161TA6813	TR	1250	760	1000	1000	700	65,5	500	200
-----------	----	------	-----	------	------	-----	------	-----	-----

Swivel castors with wheel brake or dead man's brake and foot guards for your safety

TR = Thermoplastic rubber tyres

Brake applied

Brake released



Steel-cylinder trolley  
REF 161TA6813





# Steel-cylinder trucks

## Steel-cylinder trucks

Robust welded construction; with safety handles; for easy transport of steel cylinders with a capacity of 10, 20, 40 or 50 litres; diameter 210 – 250 mm; Cylinder holder with safety chains; Powder-coated RAL 5010 gentian blue; permanent surface protection; impact- and scratch-resistant; Pneumatic or solid-rubber tyres with ball bearings



### Steel-cylinder trucks for 2 steel cylinders of 20 litres capacity

REF		Dimension			Toe plate		Weight	Load cap.	Wheel diam.
		mm			mm				
		a	b	c	d	e	kg	kg	mm
137TA1814	SR	730	572	1115	536	210	18,0	100	250×60
137TA1815	P	730	572	1115	536	210	14,0	100	260×85

P = pneumatic tyres SR = solid-rubber tyres



### Steel-cylinder trucks for 1 steel cylinder of 40 – 50 litres capacity

REF		Dimension			Toe plate		Weight	Load cap.	Wheel diam.
		mm			mm				
		a	b	c	d	e	kg	kg	mm
137TA1816	SR	463	425	1185	255	260	8,0	100	250×60
137TA1817	P	463	425	1185	255	260	7,5	100	260×85

### Steel-cylinder trucks for 1 steel cylinder with Ø 320 mm, 11 kg propan

161TA6401	SR	580	530	1200	350	340	12,0	100	250 x 60
161TA6403	P	580	530	1200	350	340	11,5	100	260 x 85

### Steel-cylinder trucks for 1 steel cylinder with Ø 320 mm, 33 kg propan

161TA6402	SR	580	530	1200	350	340	12,0	100	250 x 60
161TA6404	P	580	530	1200	350	340	11,5	100	260 x 85

Steel-rim wheels with precision deep-groove ball bearings

P = pneumatic tyres SR = solid-rubber tyres



Steel-cylinder truck  
REF 137TA1815



Steel-cylinder truck  
REF 137TA1816



Steel-cylinder truck  
REF 161TA6403



Steel-cylinder truck  
REF 161TA6402

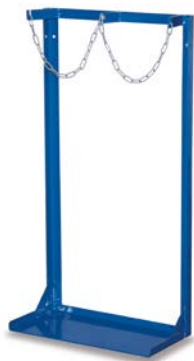

Steel-cylinder truck  
REF 161TA6218

### Steel-cylinder stand for 2 cylinders of 40 – 50 litres capacity, incl. drill holes for wall fixing

REF	Dimension			Toe plate		Weight
	mm			mm		
	a	b	c	d	e	kg
161TA6218	568	284	1100	550	280	16,0



### Additional toolbox

REF	Dimension			Weight	
	mm				
	a	b	c	kg	
161TA6264	460	205	153	fk-1300 / 1301	4,0
161TA6698	460	205	153	fk-1000	4,0
161TA6699	460	205	153	fk-1100 / 1101	4,0
161TA6700	460	205	153	fk-1302 / 1303	4,0



Toolbox  
REF 161TA6264



# Parcel trucks / Newspaper trucks



## Lightweight folding truck

Welded tubular steel; Double fold for easy transport; locking and unlocking by cable; Grip with soft plastic cover; Powder-coated RAL 5010 gentian blue, permanent surface protection; impact- and scratch-resistant; Pneumatic or solid-rubber tyres on pressed-steel wheels with ball bearings and wheel cap



folded 420 x 322 x 645 mm



Lightweight folding truck  
REF 161TA6659

## Lightweight folding truck

REF		Dimension			Toe plate		Weight	Load cap.	Wheel diam.
		mm			mm				
		a	b	c	d	e			
161TA6659	P	430	713	1165	377	455	10	80	260×85

P = pneumatic tyres

## Parcel truck and newspaper truck

Welded tubular steel; Parcel truck powder-coated RAL 5010 gentian blue; newspaper truck powder-coated RAL 3000 fire red; permanent surface protection; impact- and scratch-resistant; Pneumatic or solid-rubber tyres

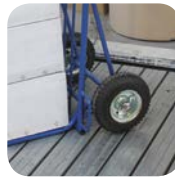

## Parcel trucks, folding toe

REF		Dimension			Toe plate		Weight	Load cap.	Wheel diam.
		mm			mm				
		a	b	c	d	e			
161TA6235	SR	540	637	1026	390	295	10,0	150	200×50
161TA6236	P	540	637	1026	390	295	10,0	150	220×70

P = pneumatic tyres SR = solid-rubber tyres



Parcel truck  
REF 161TA6235

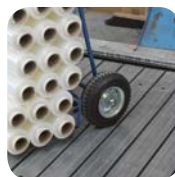

Parcel truck  
REF 161TA6237

## Parcel trucks, double-fold version

REF		Dimension			Toe plate		Weight	Load cap.	Wheel diam.
		mm			mm				
		a	b	c	d	e			
161TA6237	SR	540	637	1028	390	295	11,5	100	200×50
137TA1804	P	540	637	1028	390	295	11,0	100	220×70

P = pneumatic tyres SR = solid-rubber tyres

## Newspaper truck, folding load surface and folding sides

REF		Dimension			Toe plate		Weight	Load cap.	Wheel diam.
		mm			mm				
		a	b	c	d	e			
161TA6263	SR	673	410	1025	490	300	8,5	200	200×50

SR = solid-rubber tyres



Newspaper truck  
REF 161TA6263

**VARIOfit**<sup>®</sup>



**Drumhandling**



**Drum trucks**

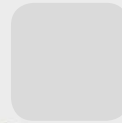

# Drum trucks



## Drum trucks

Welded tubular steel; with safety handles; for transporting drums; For all 200-litre drums with rim; only partly suitable for plastic drums; Powder-coated RAL 5010 gentian blue; permanent surface protection; impact- and scratch-resistant; Pneumatic or solidrubber tyres with ball bearings; support wheels of thermoplastic rubber with ball bearings

### Drum trucks

REF		Dimension		Loading surface	Weight	Load cap.	Wheel diam.
		mm					
		a	b				
138TA6576	SR	700	1600	for 200l drums	16,0	250	250×60
138TA6577	P	700	1600	for 200l drums	14,0	250	260×85

P = pneumatic tyres SR = solid-rubber tyres



Drum truck  
REF 138TA6577

## Drum trucks

With one supporting swivel castor from thermoplastic rubber diam. 200 x 50 mm height 1600 / 900 mm, wide 700 mm

### Drum trucks with 1 supporting swivel castor (TR)

REF		Dimension		Loading surface	Weight	Load cap.	Wheel diam.
		mm					
		a	b				
138TA6579	SR	700	1600	for 200l drums	17,0	250	250×60
138TA6578	P	700	1600	for 200l drums	15,0	250	260×85

P = pneumatic tyres SR = solid-rubber tyres



Drum truck  
REF 138TA6579



### Drum trucks with 2 supporting wheels (TR)

REF		Dimension		Weight	Load cap.	Wheel diam.
		mm				
		a	b			
136TA1012	SR	700	1600	19,0	250	250×60
138TA6580	P	700	1600	17,0	250	260×85

P = pneumatic tyres SR = solid-rubber tyres



Drum truck  
REF 136TA1012



# Drum trucks / Drum dolly

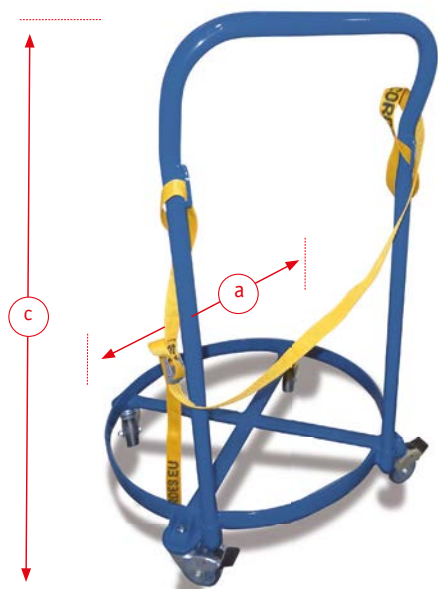

Drum dolly  
REF 161TA6809

## Drum dolly with push bar

For easy transport of 200-litre drums; with load securing strap; Surface powder-coated RAL 5010 gentian blue; permanent surface protection; impact and scratch resistant

### Drum dolly with push bar

REF		Dimensions		Load cap.	Weight	Load cap.	Wheel diam.
		mm			kg	kg	mm
		a	c				
161TA6809	TR	610	930	for 200-litre drums	13	250	75

**Incl. webbing strap for securing drum**  
TR = Thermoplastic rubber tyres



Drum dolly  
REF 138TA6572

## Drum dolly

Welded steel construction; For upright transport of 200-litre drums; Powder-coated RAL 5010 gentian blue; permanent surface protection; impact- and scratch resistant; 4 thermoplastic rubber tyres with plain bearings, incl. 2 with wheel brakes

### Drum dolly

REF	Dimension	Weight	Load cap.	Wheel diam.
	diam. mm	kg	kg	mm
138TA6572	610	7,0	250	75

## Drum truck

Welded tubular steel; with plastic skids and safety handles; Webbing strap for securing load; Surface powder-coated RAL 5010 gentian blue; permanent surface protection; impact- and scratch-resistant; Solid rubber tyres on steel wheels with precision deep-groove ball bearings

Suitable for transporting  
120-220 litre plastic drums

Liquid can be drained in horizontal position



Drum truck  
REF 161TA6771



### Drum truck for plastic drums

REF		Dimensions			Load cap.	Weight	Load cap.	Wheel diam.
		mm				kg	kg	mm
		a	b	c				
161TA6771	SR	640	470	1300	for 200-litre drums	17	250	250
161TA6772	P	640	470	1300	for 200-litre drums	16	250	260

**Steel wheels with precision deep-groove ball bearings, webbing strap for securing drums**  
SR = solid rubber tyres, P = pneumatic tyres

# Drum dispenser

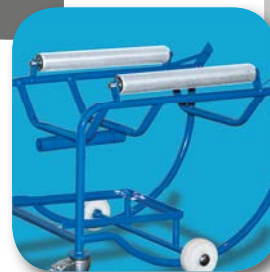

## Drum dispensers

Welded tubular steel construction; with lever handle; for moving, storing and emptying 200-litre steel drums; Powder-coated RAL 5010 gentian blue; permanent surface protection; 2 polyamide swivel castors with wheel brakes 100 x 38 mm and 2 polyamide wheels 125 x 40 mm; The drum rests either on 4 plastic wheels or in the case of thin-walled drums, on 2 steel rollers

### Drum dispenser with 4 plastic wheels

REF	Dimension			Loading surface	Weight	Load cap.	Wheel diam.
	mm						
	a	b	c		kg	kg	mm
138TA6573	810	720	575	for 200l drums	13,0	250	125

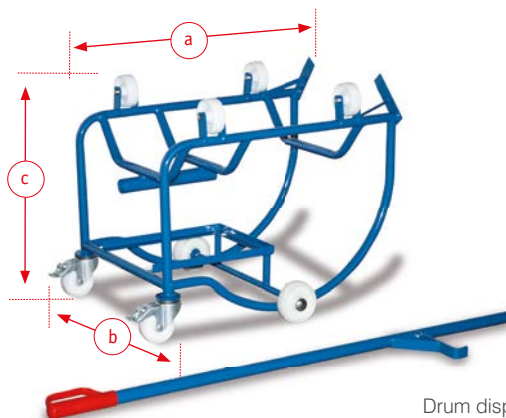

Drum dispenser  
REF 138TA6573

### Additional Articles

Art. REF. no.	
138TA6575	10 l Drip trays



Drum dispenser like zu-3201, but with 2 steel rollers diam. 60 mm, Length 500 mm, for thin-walled drums.

### Drum dispenser with 2 steel rollers 60 x 500 mm, for thin-walled drums

REF	Dimension			Loading surface	Weight	Load cap.	Wheel diam.
	mm						
	a	b	c		kg	kg	mm
161TA6163	810	720	575	for 200l drums	22,0	250	125

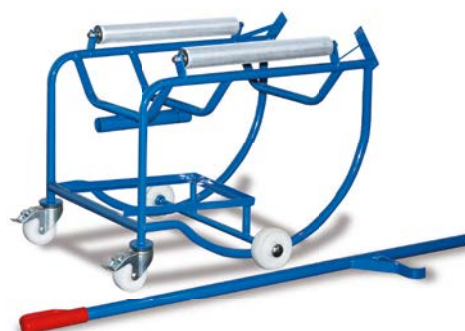

Drum dispenser  
REF 161TA6163

Drum dispenser like zu-3202, but with big Drip tray 203 liter, on 2 wheels diam. 125mm, W1450 x D 480 x H 300 mm.

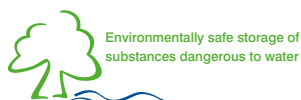

### Drum dispenser with drip tray 203 litres capacity

REF	Dimension			Loading surface	Weight	Load cap.	Wheel diam.
	mm						
	a	b	c		kg	kg	mm
138TA6574	1450	720	650	for 200l drums	79,0	250	125



Drum dispenser  
REF 138TA6574



Environmentally safe storage of substances dangerous to water

# Drip trays

## Drip trays

Welded steel oil-tight; with galvanised grating; mesh size 30 x 30 mm; for 2 or 4 x 200-litre drums; Incl. 4 feet; ground clearance = 100 mm; Trough powder-coated RAL 5010 gentian blue; permanent surface protection; impact- and scratch-resistant

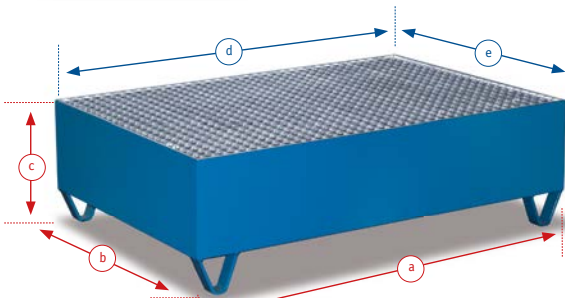

Drip tray  
REF 138TA8238

### Drip tray with grating for 2 x 200-litre drums

REF	Dimension			Loading surface		Weight kg	Load cap. kg
	a	b	c	d	e		
138TA8238	1200	800	360	1200	800	69,5	500



Drip tray  
REF 138TA8240

### Drip tray with grating for 4 x 200-litre drums

REF	Dimension			Loading surface		Weight kg	Load cap. kg
	a	b	c	d	e		
138TA8240	2390	790	250	2390	790	110,5	1000



Outlet cock for Articles on pages 53, 92, 93, 95

REF	
161TA6701	Outlet cock, for draining liquids for articles with sheet-steel trough as ex-factory equipment

### Drip tray with grating for 4 x 200-litre drums

REF	Dimension			Loading surface		Weight kg	Load cap. kg
	a	b	c	d	e		
138TA8239	1200	1200	285	1200	1200	85,0	1000

Drip tray  
REF 138TA8239



# Stacking frame with drip tray / Pushbar trolley with drip tray



## Stacking frame with drip tray

Stacking frame, strong welded steel construction, 4 push-in posts with stacking ends inclined inwards; 4 connecting tubes; steel pan with galvanized grating for collecting liquids; volume 230 l; powder-coated RAL 5010 gentian blue; durable surface protection; impact and scratch resistant; stacking feet flush with frame; 8 stacking supports



### Stacking frame with drip tray

REF	Dimension			Loading surface		Weight	Load cap.	Top Load	stackable
	mm			mm					
	a	b	c	d	e	kg	kg	kg	
161TA6770	1250	1250	1400	1124	1124	219	2400	1000	3x

Stacking frame with drip tray  
REF 161TA6770

## Pushbar trolley with drip tray

Welded steel oil tight; Sheet-steel trough; capacity 42.5 litres; galvanised grating, mesh size 30 x 30 mm; Trolley powder-coated RAL 5010 gentian blue; permanent surface protection; impact and scratch-resistant; Grey non-marking thermoplastic rubber tyres with precision deep-groove ball bearings; thread and foot guard; 2 swivel castors with wheel brakes and 2 fixed castors



### Pushbar trolley with drip tray

REF	Dimension			Loading surface		Weight	Load cap.	Wheel diam.
	mm			mm				
	a	b	c	d	e	kg	kg	mm
139TA1925	1098	600	941	986	586	42,0	250	125

Pushbar trolley  
REF 139TA1925



# Cleaning trolley / Waste collection stand



## Cleaning trolley

Welded steel construction; with lockable sheetsteel compartment; with holders for plastic sacks and cleaning tools; Pushbars with plastic safety handles; Surface powder-coated RAL 2009 traffic orange; permanent surface protection; impact- and scratch-resistant; Rear axle with two 400-mm pneumatic castors on steel wheels; front axle with 2 thermoplastic castors 160 mm

## Cleaning trolley

REF	Dimensions			Weight	Load cap.	Wheel diam.
	mm					
	a	b	c	kg	kg	mm
161TA6816	780	800	1030	32	100	400

incl. steel compartment with triangular lock



Waste collection stand  
REF 161TA6793



Waste collection stand  
REF 161TA6794

## Waste collection stand

Welded tubular steel; holder for 240-litre plastic sacks; foldable open frame for securing waste collection sack; sack opening with 40° inclination; surface powder-coated RAL 5010 gentian blue; permanent surface protection; impact- and scratch-resistant

## Waste collection stand

REF	Dimensions			Load cap.	Weight
	mm				
	a	b	c	ltr.	kg
161TA6793	630	540	1190	240	14
161TA6794	470	320	1190	240	12

Sack opening with 40° inclination



Roll stand  
REF 161TA6788

## Roll stand for storing material on rolls

Strong welded steel design; chrome-plated loading bar; loading height 800 mm; painted 5012 light blue

## Roll stand for storing material on rolls

REF	Dimensions			loading height	Weight	Load cap.
	mm					
	a	b	c	mm	kg	kg
161TA6788	1630	1000	1200	800	22,5	100

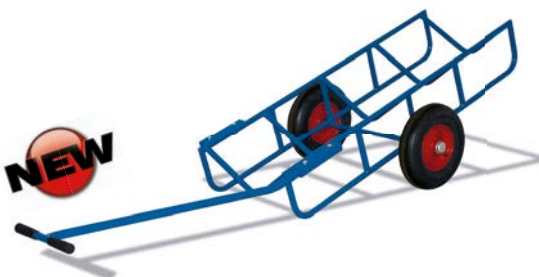

Roll truck  
REF 161TA6789

## Roll truck

Strong welded steel design; pullbar with horizontal handle; powder coated RAL 5010 gentian blue; durable surface protection; impact and scratch resistant; wheels with pneumatic tyres on steel rims with ball bearings

## Roll truck for transporting rolls in horizontal position

REF	Dimensions			Weight	Load cap.	Wheel diam.
	mm					
	a	b	c	kg	kg	mm
161TA6789	2700	820	840	30,0	400	400 x 100

# Self-tippers for bulk material



**VARIOfit**  
 The perfect form  
 of transport

## Self-tipper for bulk material

Welded steel construction; with roll-away system; Tipping by manual release or by contact with container to be filled; Automatic return after trough is emptied; Fork-lift tunnel for safe transport; Painted RAL 5012 light blue; Facility for retrofitting wheels; Various wheel types with different carrying capacities available as options



Self-tipper  
REF 161TA6662

### Self-tipper

REF	Dimension			inner height mm	Bulk-edge height	Weight kg	Load cap. kg	Volume l
	mm							
	a	b	c					
161TA6662	1235	840	750	420	750	83	1500	300
147TA3496	1350	1488	605	480	605	121	1500	520
161TA6672	1512	860	866	735	866	108	2000	600
161TA6660	1498	1203	1072	940	1072	167	2000	1000

### Additional Articles (wheelset)

REF		Load cap. kg	Wheel diam. mm
161TA6701	Outlet cock	-	-
147TA3497	Wheel with thermoplastic rubber	500	200
161TA6648	Polyamide wheels	1050	200
161TA6649	Elastic-solid-rubber wheels	1050	200
161TA6650	Polyurethane wheels 92°	1500	200
161TA6651	Polyurethane wheels 92°	2000	200

The type of wheels used may reduce the carrying capacity.



Thermoplastic rubber wheels



Polyamide wheels



Elastic-solid-rubber wheels



Polyurethane wheels

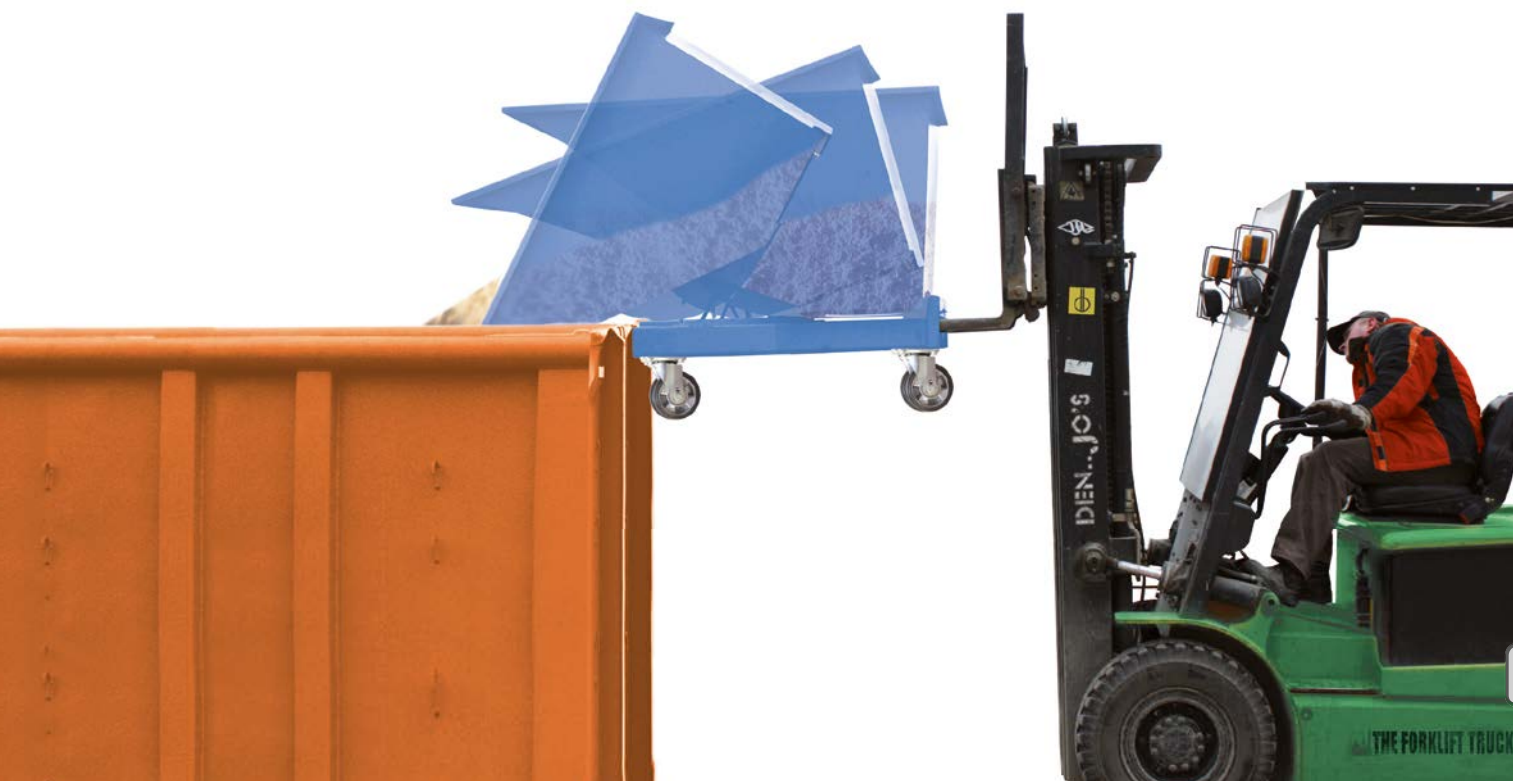



**VARIOfit**<sup>®</sup>



**Hand trucks**



**Bicycle trailers**

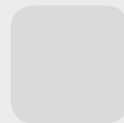
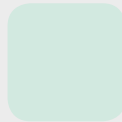

# Hand trucks / Bicycle trailers



VARIOfit®  
The perfect form  
of transport

## Hand trucks

Welded steel construction; with optional side walls; railing 220 mm high; with reflective films; load surface and side walls of waterproof bonded plywood, surface finish screen printed, anti-slip; Truck powder-coated RAL 5010 gentian blue; permanent surface protection; impact- and scratch-resistant; Wheels with pneumatic tyres and ball bearings

### Hand trucks without side walls

REF	Loading surface		Total width	Weight	Load cap.	Wheel diam.
	d	e				
138TA4090	790	435	740	21,0	200	260×85
138TA4091	830	535	840	25,0	400	400×100
138TA4092	1130	535	840	30,0	400	400×100
138TA4093	1000	635	940	34,0	400	400×100

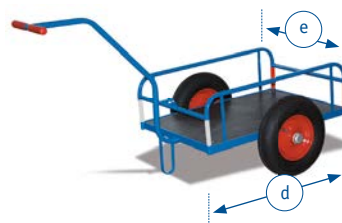

Hand truck  
REF 138TA4090

### Hand trucks with side walls

REF	Loading surface		Total width	Weight	Load cap.	Wheel diam.
	d	e				
138TA4086	765	435	740	24,0	200	260×85
138TA4087	805	535	840	28,0	400	400×100
138TA4088	1105	535	840	34,0	400	400×100
138TA4089	975	635	940	38,0	400	400×100



Hand truck  
REF 138TA4086

## Bicycle trailer

With optional side walls; all bicycle trailers are supplied with complete trailer coupling; the ball socket is welded to the towbar; the ball head with clamp is supplied loose for the user to fit to the cycle frame; with reflective films; Load surface and side walls of waterproof bonded plywood, surface finish screen printed, anti-slip; Trolley powder-coated RAL 5010 gentian blue; permanent surface protection; impact- and scratch-resistant; Wheels with pneumatic tyres and ball bearings



including trailer coupling

### Bicycle trailer without side walls

REF	Loading surface		Total width	Weight	Load cap.	Wheel diam.
	d	e				
138TA4078	790	435	740	21,0	200	260×85
138TA4079	830	535	840	25,0	400	400×100
138TA4080	1130	535	840	30,0	400	400×100



Bicycle trailer  
REF 138TA4078

### Bicycle trailers with side walls

REF	Loading surface		Total width	Weight	Load cap.	Wheel diam.
	d	e				
138TA4081	765	435	740	24,0	200	260×85
138TA4082	805	535	840	25,0	400	400×100
138TA4083	1105	535	840	34,0	400	400×100



Bicycle trailer  
REF 138TA4081

## Lightweight bicycle trailer and lightweight hand truck

Especially light body; with reflective films; load surface and side walls of waterproof bonded plywood, surface finish screen printed, anti-slip; Total width 640 mm; Truck powder-coated RAL 5010 gentian blue; permanent surface protection; impact- and scratch-resistant; Wheels with pneumatic tyres and ball bearings

### Light bicycle trailer with side walls

REF	Loading surface		Total width	Weight	Load cap.	Wheel diam.
	d	e				
138TA4084	700	425	640	15,0	150	310×50



Light bicycle trailer  
REF 138TA4084

### Light hand truck with side walls

REF	Loading surface		Total width	Weight	Load cap.	Wheel diam.
	d	e				
138TA4085	700	425	640	15,0	150	310×50



Light hand truck  
REF 138TA4085

Bicycle trailer only for material-transport.  
Only for internal transport.



# Hand platform trolleys

## Hand platform trolleys

Welded steel construction; optional side walls or tubular grid; with reflective films; with turntable steering and ball-bearing steering rings; Automatic parking brake acting on front wheels; Drawbar with safety handle and soft grip cover; automatically damped return to rest position; Multi-ply waterproof bonded plywood, surface finish screen printed, anti-slip; Powder-coated RAL 5010 gentian blue; permanent surface protection; impact- and scratch-resistant; Pneumatic or solid-rubber tyres

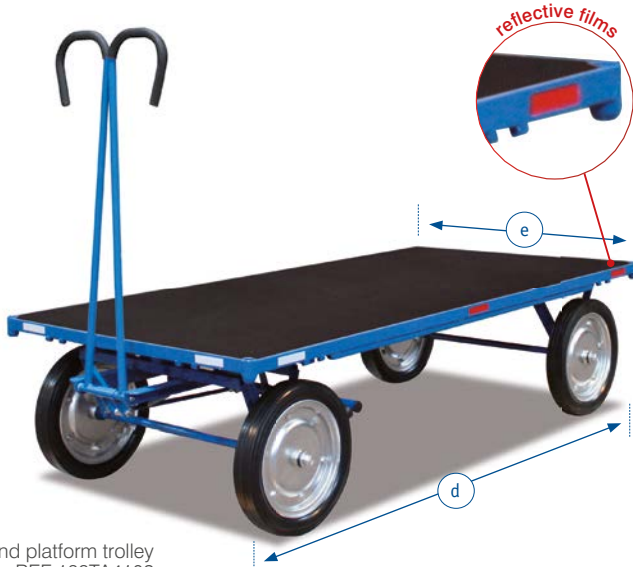

Hand platform trolley  
REF 138TA4102

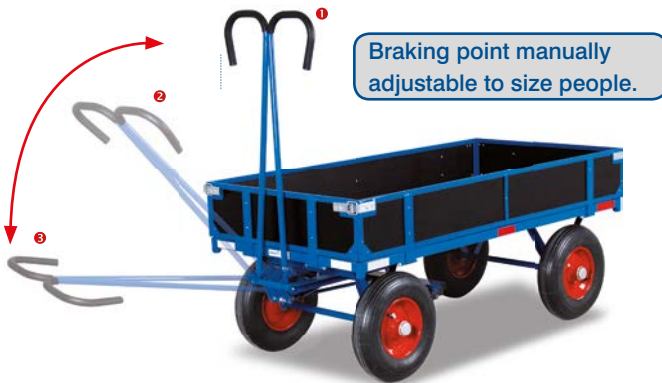

Hand platform trolley  
REF 138TA4109

### Hand platform trolleys without side walls / Loading height 410 mm

REF		Loading surface		Weight	Load cap.	Wheel diam.
		mm	mm			
		d	e			
138TA4094	SR	1000	700	59,0	700	250×60
138TA4095	P	1000	700	53,0	700	260×85
138TA4096	SR	1200	800	68,0	700	250×60
138TA4097	P	1200	800	62,0	700	260×85

P = pneumatic tyres SR = solid-rubber tyres

### Hand platform trolleys without side walls / Loading height 480 mm

REF		Loading surface		Weight	Load cap.	Wheel diam.
		mm	mm			
		d	e			
138TA4098	SR	1200	800	92,0	1000	400×80
138TA4099	P	1200	800	68,0	1000	400×100
138TA4100	SR	1600	800	98,0	1000	400×80
138TA4101	P	1600	800	74,0	1000	400×100
138TA4102	SR	2000	1000	136,0	1250	400×80
138TA4103	P	2000	1000	112,0	1250	400×100

P = pneumatic tyres SR = solid-rubber tyres



Automatic parking brake acting on front wheels and drawbar with safety handle and automatically damped return to rest position

### Hand platform trolleys with side walls, height 220 mm / Loading height 410 mm

REF		Loading surface		Weight	Load cap.	Wheel diam.
		mm	mm			
		d	e			
138TA4104	SR	960	660	76,0	700	250×60
138TA4105	P	960	660	70,0	700	260×85
138TA4106	SR	1160	760	87,0	700	250×60
138TA4107	P	1160	760	81,0	700	260×85

P = pneumatic tyres SR = solid-rubber tyres

### Hand platform trolleys with 4 tubular grid side walls, height 750 mm / Loading height 480 mm

REF		Loading surface		Weight	Load cap.	Wheel diam.
		mm	mm			
		d	e			
138TA4108	SR	1160	760	111,0	1000	400×80
138TA4109	P	1160	760	87,0	1000	400×100
138TA4110	SR	1560	760	122	1000	400×80
138TA4111	P	1560	760	98,0	1000	400×100
138TA4112	SR	1960	960	150,0	1250	400×80
138TA4113	P	1960	960	126,0	1250	400×100

P = pneumatic tyres SR = solid-rubber tyres





**Hand platform trolleys with 2 tubular grid side walls, height 750 mm / Loading height 410 mm**

REF		Loading surface		Weight	Load cap.	Wheel diam.
		mm	mm			
		d	e	kg	kg	mm
138TA4114	SR	930	700	76,0	700	250×60
138TA4115	P	930	700	70,0	700	260×85
138TA4116	SR	1130	800	87,0	700	250×60
138TA4117	P	1130	800	81,0	700	260×85

P = pneumatic tyres SR = solid-rubber tyres

**Hand platform trolleys with 2 tubular grid side walls, height 750 mm / Loading height 480 mm**

REF		Loading surface		Weight	Load cap.	Wheel diam.
		mm	mm			
		d	e	kg	kg	mm
138TA4118	SR	1130	800	111,0	1000	400×80
138TA4119	P	1130	800	87,0	1000	400×100
138TA4120	SR	1530	800	119,0	1000	400×80
138TA4121	P	1530	800	95,0	1000	400×100
138TA4122	SR	1930	1000	144,0	1250	400×80
138TA4123	P	1930	1000	120,0	1250	400×100

P = pneumatic tyres SR = solid-rubber tyres



Hand platform trolley  
REF 138TA4119

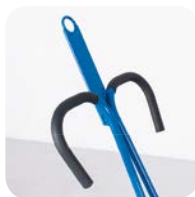

**Additional Articles**

Art. REF.	No.
101TA6304	drawbar eye on drawbar
101TA6345	coupling at the end

**Hand platform trolleys with 4 tubular grid side walls, height 750 mm / Loading height 410 mm**

REF		Loading surface		Weight	Load cap.	Wheel diam.
		mm	mm			
		d	e	kg	kg	mm
138TA4124	SR	930	630	86,0	700	250×60
138TA4125	P	930	630	80,0	700	260×85
138TA4126	SR	1130	730	101,0	700	250×60
138TA4127	P	1130	730	95,0	700	260×85

P = pneumatic tyres SR = solid-rubber tyres

**Hand platform trolleys with 4 tubular grid side walls, height 750 mm / Loading height 480 mm**

REF		Loading surface		Weight	Load cap.	Wheel diam.
		mm	mm			
		d	e	kg	kg	mm
138TA4128	SR	1130	730	125,0	1000	400×80
138TA4129	P	1130	730	101,0	1000	400×100
138TA4130	SR	1530	730	141,0	1000	400×80
138TA4131	P	1530	730	117,0	1000	400×100
138TA4132	SR	1930	930	174,0,0	1250	400×80
138TA4133	P	1930	930	150,0	1250	400×100

P = pneumatic tyres SR = solid-rubber tyres



Hand platform trolley  
REF 138TA4129



# Industrial trailers

## 1-axle turntable steering

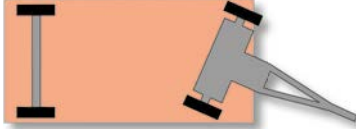

Industrial trailer  
REF 138TA4161

## 2-axle turntable steering

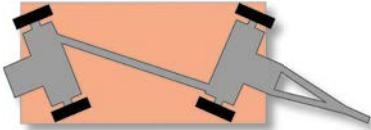

Industrial trailers  
REF 138TA4186

## 4-axle turntable steering

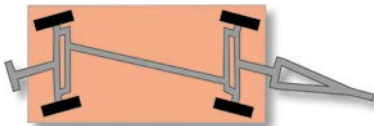

Industrial trailers  
REF 161TA6726

### Industrial trailers 1-axle turntable steering

REF	Loading surface	LadeHeight		Load cap.	Wheel diam.	
		mm	mm			
		d	e	kg	mm	
138TA4160	SR	2000	1000	510	2000	360×60
138TA4161	P	2000	1000	540	2000	410×110
138TA4162	SR	2500	1250	510	2000	360×60
138TA4163	P	2500	1250	540	2000	410×110
138TA4164	SR	3000	1500	510	2000	360×60
138TA4165	P	3000	1500	540	2000	410×110
138TA4166	SR	2000	1000	530	3000	400×75
138TA4167	P	2000	1000	560	3000	460×140
138TA4168	SR	2500	1250	530	3000	400×75
138TA4169	P	2500	1250	560	3000	460×140
138TA4170	SR	3000	1500	530	3000	400×75
138TA4171	P	3000	1500	560	3000	460×140
138TA4172	SR	2000	1000	530	5000	400×130
138TA4173	P	2000	1000	700	5000	530×160
138TA4174	SR	2500	1250	530	5000	400×130
138TA4175	P	2500	1250	700	5000	530×160
138TA4176	SR	3000	1500	530	5000	400×130
138TA4177	P	3000	1500	700	5000	530×160
138TA4178	SR	2500	1250	540	8000	415×200
138TA4179	SR	3000	1500	540	8000	415×200
138TA4180	SR	4000	2000	540	8000	415×200
138TA4181	SR	5000	2000	540	8000	415×200

P = pneumatic tyres SR = solid-rubber tyres

### Industrial trailers 2-axle turntable steering

REF	Loading surface	LadeHeight		Load cap.	Wheel diam.	
		mm	mm			
		d	e	kg	mm	
138TA4185	SR	2000	1000	510	2000	360×60
138TA4186	P	2000	1000	540	2000	410×110
138TA4187	SR	2500	1250	510	2000	360×60
138TA4188	P	2500	1250	540	2000	410×110
138TA4189	SR	3000	1500	510	2000	360×60
138TA4190	P	3000	1500	540	2000	410×110
138TA4191	SR	2000	1000	530	3000	400×75
138TA4192	P	2000	1000	560	3000	460×140
138TA4193	SR	2500	1250	530	3000	400×75
138TA4194	P	2500	1250	560	3000	460×140
138TA4195	SR	3000	1500	530	3000	400×75
138TA4196	P	3000	1500	560	3000	460×140
138TA4197	SR	2000	1000	530	5000	400×130
138TA4198	P	2000	1000	700	5000	530×160
138TA4199	SR	2500	1250	530	5000	400×130
138TA4200	P	2500	1250	700	5000	530×160
138TA4201	SR	3000	1500	530	5000	400×130
138TA4202	P	3000	1500	700	5000	530×160

P = pneumatic tyres SR = solid-rubber tyres

### Industrial trailers 4-axle turntable steering

REF	Loading surface	LadeHeight		Load cap.	Wheel diam.	
		mm	mm			
		d	e	kg	mm	
161TA6725	SR	2000	1000	510	2000	360×60
161TA6726	P	2000	1000	540	2000	410×110
161TA6727	SR	2500	1250	510	2000	360×60
161TA6728	P	2500	1250	540	2000	410×110
161TA6729	SR	3000	1500	510	2000	360×60
161TA6730	P	3000	1500	540	2000	410×110
161TA6731	SR	2000	1000	530	3000	400×75
161TA6732	P	2000	1000	560	3000	460×140
161TA6733	SR	2500	1250	530	3000	400×75
161TA6734	P	2500	1250	560	3000	460×140
161TA6735	SR	3000	1500	530	3000	400×75
161TA6736	P	3000	1500	560	3000	460×140
161TA6737	SR	2000	1000	530	5000	400×130
161TA6738	P	2000	1000	700	5000	530×160
161TA6739	SR	2500	1250	530	5000	400×130
161TA6740	P	2500	1250	700	5000	530×160
161TA6741	SR	3000	1500	530	5000	400×130
161TA6742	P	3000	1500	700	5000	530×160

P = pneumatic tyres SR = solid-rubber tyres



**Industrial trailers**

Extremely robust, pulse-welded steel-section construction; with rounded corners; the steering system is of turntable design with heavy-duty precision deep-groove ball-bearing; steering ring with safety stop in accordance with German accident prevention regulations (UVV); Maximum speed: 6 km/h; Painted RAL 2004 pure orange; Heavy-duty wheels in robust welded-steel construction with elastic solid-rubber tyres or heavy-duty pneumatic wheels with industrial tread; Welded drawbar with retaining system in accordance with German accident prevention regulations (UVV) (for safety reasons all drawbars are pulse-welded, as this permits very homogeneous welds). Standard drawbar eye for 35 mm coupling bolt (offset drawbars or drawbars with swivel eyes also available on request); Caution: if the customer does not specify the height of the drawbar jaw, we accept no liability for ease of coupling of the trailer; The wheels are heavy-duty pneumatic wheels with industrial tread or heavy-duty wheels of unbreakable welded steel construction with elastic solid-rubber tyres; The hubs are fitted with dustproof encapsulated, pre-lubricated bearings in accordance with DIN ISO 355 or 15-1981; Painted RAL 2004 pure orange

**Four push-fit stanchions for industrial trailer**

REF	
138TA4182	Four push-fit stanchions

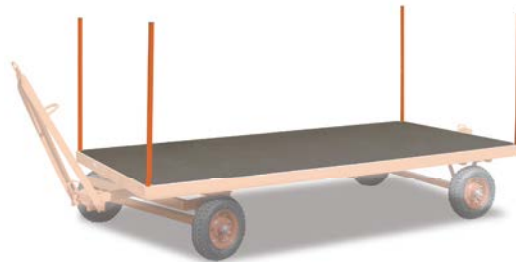

Four push-fit stanchions  
REF 138TA4182

**Side walls for industrial trailer**

REF	Loading surface		
	mm		
	d	e	
161TA6277	2000	1000	
138TA4183	2500	1250	4 Side walls for industrial trailer
138TA4184	3000	1500	

as ex-factory equipment;  
not additionally mountable



Side walls  
REF 161TA6277

**Two tubular-steel end walls for industrial trailer, 750 mm high, removable**

REF	Loading surface		
	mm		
	d	e	
138TA4203	2000	1000	
138TA4204	2500	1250	Two tubular-steel end walls 750 mm high
138TA4205	3000	1500	

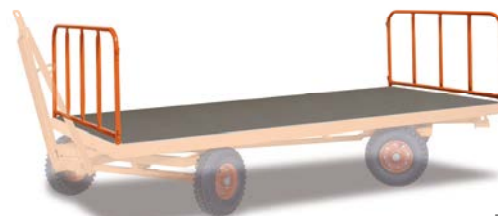

Two tubular-steel end walls  
REF 138TA4203

**Four tubular-steel walls for industrial trailer, 750 mm high, removable, sides insertable**

REF	Loading surface		
	mm		
	d	e	
138TA4206	2000	1000	Four tubular-steel walls 750 mm high, removable
138TA4207	2500	1250	
138TA4208	3000	1500	



Four tubular-steel walls  
REF 138TA4206





# Two-wheeled platforms / Safety quick-lift jack

Safety quick-lift jack  
REF 138TA4073



## Safety quick-lift jack

With locking system; reliable engagement with two-wheeled platform; Elastic solid-rubber wheels; ball-bearing hubs

### Safety quick-lift jack

REF	Load cap.		Wheel diam.
	kg	for wheeled platforms with Load cap. kg	
138TA4073	500	1000	180
138TA4074	750	1500	250
138TA4075	1000	2000	250
138TA4076	1500	3000	250

Suitable only for two-wheeled platforms on page 100



Two-wheeled platform  
REF 138TA4043

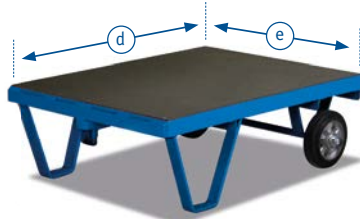

## Two-wheeled platform

2 support runners; socket with safety catch; Load surface of waterproof bonded plywood, surface finish screen printed, anti-slip; Powder-coated RAL 5010 gentian blue; permanent surface protection; impact- and scratch-resistant; Elastic solid-rubber or polyurethane tyres; ball bearings; mounted on a single axle

### Two-wheeled platforms

REF		Loading surface		Weight kg	Load cap. kg	Wheel diam. mm
		mm				
		d	e			
138TA4043	ER	1005	700	55	1000	200
138TA4044	ER	1205	800	58	1000	200
138TA4045	ER	1605	900	62	1000	200
138TA4046	ER	2005	1000	67	1000	200

ER = Elastic-solid-rubber wheels

### Two-wheeled platforms, reinforced version with large wheels

REF		Loading surface		Weight kg	Load cap. kg	Wheel diam. mm
		mm				
		d	e			
138TA4047	ER	1005	700	56	1500	250
138TA4048	ER	1205	800	59	1500	250
138TA4049	ER	1605	900	63	1500	250
138TA4050	ER	2005	1000	69	1500	250
138TA4051	ER	2505	800	75	1500	250
138TA4052	PO	1205	800	63	2000	250
138TA4053	PO	1605	900	68	2000	250
138TA4054	PO	2005	1000	74	2000	250
138TA4055	PO	2505	800	80	2000	250
138TA4056	PO	1205	800	64	3000	250
138TA4057	PO	1605	900	69	3000	250
138TA4058	PO	2005	1000	75	3000	250
138TA4059	PO	2505	800	81	3000	250

ER = Elastic-solid-rubber wheels, PO = Polyurethane wheels

Two-wheeled platform  
REF 138TA4047



### Two-wheeled platform with additional tubular bearers as reinforcement

Art. REF. no.		Loading surface		Weight kg	Load cap. kg	Wheel diam. mm
		mm				
		d	e			
138TA4060	ER	3305	800	97	1500	250
138TA4061	ER	4005	800	116	1500	250
138TA4062	PO	3305	800	104	2000	250
138TA4063	PO	4005	800	124	2000	250
138TA4064	PO	3305	800	105	3000	250
138TA4065	PO	4005	800	126	3000	250

ER = Elastic-solid-rubber wheels, PO = Polyurethane wheels

Two-wheeled platform  
REF 138TA4060





### Quick-lift jack

With ball head; ball without safety catch



Quick-lift jack  
REF 138TA4077

#### Quick-lift jack

REF	Weight		Load cap.	Wheel diam.
	kg		kg	mm
138TA4077	7,0		500	200×50

Suitable only for two-wheeled platforms on page 103

### Two-wheeled platforms

Welded steel construction; with 2 support runners; ball head without safety catch; Platform and optional walls of wood-based board, surface finish beech; Walled version has stacking corners with locating cups; walls permanently riveted; Powder-coated RAL 5010 gentian blue; permanent surface protection; impact- and scratch-resistant; 2 fixed castors of thermoplastic rubber with precision deep-groove ball bearings

#### Two-wheeled platforms

REF	Dimension		Weight	Load cap.	Wheel diam.			
	mm					kg	kg	mm
	d	e						
138TA4066	900	500	38	500	200×50			
138TA4067	1000	700	41	500	200×50			
129TA5641	1200	800	43	500	200×50			
138TA4068	1600	900	46	500	200×50			



Two-wheeled platform  
REF 138TA4066

Two-wheeled platforms with end walls, stacking height 550 mm, usable height 290 mm, stackable four high when unloaded

REF	Dimension		Weight	Load cap.	Wheel diam.			
	mm					kg	kg	mm
	d	e						
138TA4069	1000	700	47	500	200×50			
138TA4070	1200	800	49	500	200×50			



Two-wheeled platform  
REF 138TA4069

Two-wheeled platform with 4 walls, stacking height 550 mm, usable height 290 mm, stackable four high when unloaded

REF	Dimension		Weight	Load cap.	Wheel diam.			
	mm					kg	kg	mm
	d	e						
138TA4071	1000	700	52	500	200×50			
138TA4072	1200	800	54	500	200×50			



Two-wheeled platform  
REF 138TA4071

# Steel-frame dollies for pallets



## Steel-frame dollies for pallets

Robust welded steel construction; for Euro pallets or cage pallets; also available with 2 angle-steel frames; Incl. locating cups and lifting rings; Powder-coated RAL 5010 gentian blue; permanent surface protection; impact- and scratch-resistant; Grey non-marking thermoplastic rubber tyres or elastic solid-rubber tyres on cast aluminium wheels; with precision deep-groove ball bearings; thread and foot guard; 2 swivel castors with wheel brakes and 2 fixed castors

**VARIOfit**  
The perfect form  
of transport

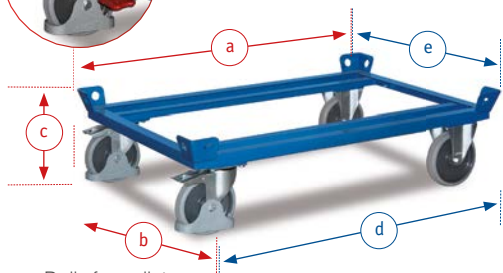

Dolly for pallets  
REF 138TA4003



Dolly for pallets  
REF 138TA4004



Dolly for pallets  
REF 161TA6835



Dolly for pallets  
REF 161TA6838

### Steel frame dollies for cage pallets 500kg carrying capacity

REF		Dimension			Loading surface		Weight kg	Load cap. kg	Wheel diam. mm
		a	b	c	d	e			
161TA6547	TR	870	670	350	800	600	25,0	500	200
161TA6544	TR	1070	870	350	1000	800	30,0	500	200
138TA4003	TR	1270	870	350	1200	800	32,5	500	200
161TA6545	TR	1270	1070	350	1200	1000	33,0	500	200

### Steel frame dollies for cage pallets 500kg carrying capacity with EasySTOP

161TA6825	TR	870	670	350	800	600	25,0	500	200
161TA6822	TR	1070	870	350	1000	800	30,0	500	200
161TA6819	TR	1270	870	350	1200	800	32,5	500	200
161TA6823	TR	1270	1070	350	1200	1000	33,0	500	200

Swivel castors with foot guards for your safety.

TR = Thermoplastic rubber tyres

### Steel frame dollies for cage pallets 1200kg carrying capacity

REF		Dimension			Loading surface		Weight kg	Load cap. kg	Wheel diam. mm
		a	b	c	d	e			
161TA6548	ER	870	670	350	800	600	29,0	1200	200
161TA6546	ER	1070	870	350	1000	800	34,0	1200	200
138TA4004	ER	1270	870	350	1200	800	36,0	1200	200
161TA6553	ER	1270	1070	350	1200	1000	37,0	1200	200

### Steel frame dollies for cage pallets 1200kg carrying capacity with EasySTOP

161TA6826	ER	870	670	350	800	600	29,0	1200	200
161TA6824	ER	1070	870	350	1000	800	34,0	1200	200
161TA6820	ER	1270	870	350	1200	800	36,0	1200	200
161TA6821	ER	1270	1070	350	1200	1000	37,0	1200	200

Swivel castors with foot guards for your safety.

ER = Elastic-solid-rubber wheels

### Steel frame dollies for cage pallets 1800kg carrying capacity (92° Shore reinforced version)

REF		Dimension			Loading surface		Weight kg	Load cap. kg	Wheel diam. mm
		a	b	c	d	e			
161TA6837	PO	870	670	350	800	600	29,0	1800	200
161TA6836	PO	1070	870	350	1000	800	34,0	1800	200
161TA6835	PO	1270	870	350	1200	800	36,0	1800	200
161TA6842	PO	1270	1070	350	1200	1000	37,0	1800	200

### Steel frame dollies for cage pallets 1800kg carrying capacity (92° Shore reinforced version) with EasySTOP

161TA6827	PO	870	670	350	800	600	29,0	1800	200
161TA6828	PO	1070	870	350	1000	800	34,0	1800	200
161TA6829	PO	1270	870	350	1200	800	36,0	1800	200
161TA6830	PO	1270	1070	350	1200	1000	37,0	1800	200

Swivel castors with foot guards for your safety.

PO = Polyurethane wheels

### Steel frame dollies for cage pallets 1050kg carrying capacity

REF		Dimension			Loading surface		Weight kg	Load cap. kg	Wheel diam. mm
		a	b	c	d	e			
161TA6841	PW	870	670	350	800	600	25,0	1050	200
161TA6839	PW	1070	870	350	1000	800	30,0	1050	200
161TA6838	PW	1270	870	350	1200	800	32,5	1050	200
161TA6840	PW	1270	1070	350	1200	1000	33,0	1050	200

### Steel frame dollies for cage pallets Fahrgestell für 1050kg carrying capacity with EasySTOP

161TA6831	PW	870	670	350	800	600	25,0	1050	200
161TA6832	PW	1070	870	350	1000	800	30,0	1050	200
161TA6833	PW	1270	870	350	1200	800	32,5	1050	200
161TA6834	PW	1270	1070	350	1200	1000	33,0	1050	200

Swivel castors with foot guards for your safety.

PW = Polyamide wheels



# Accessories

## Add-on frame for pallet dolly

Strong steel construction; including 4 locating corners; height adjustment by internal spring-loaded bolt; add-on frame can be bolted to dolly

### Add-on frame, height adjustable, (505 / 555 / 605 / 650 mm), retrofittable

REF	Dimension		Loading surface		Weight	Load cap.
	mm		mm			
	a	b	d	e		
161TA6883	870	670	800	600	14,5	500 - 1200
161TA6884	1070	870	1000	800	16,0	500 - 1200
161TA6885	1270	870	1200	800	17,0	500 - 1200
161TA6886	1270	1070	1200	1000	17,5	500 - 1200

loading height  
650 mm  
605 mm  
555 mm  
505 mm



Add-on frame  
REF 161TA6885

## Steel frame dollies with 2 angle-steel frames, 1200kg carrying capacity

REF		Dimension			Loading surface		Weight	Load cap.	Wheel diam.
		mm			mm				
		a	b	c	d	e			
161TA6551	ER	870	670	721	800	600	45,0	1200	200
161TA6552	ER	1070	870	721	1000	800	49,0	1200	200
sw-870.101	ER	1270	870	721	1200	800	53,0	1200	200
161TA6555	ER	1270	1070	721	1200	1000	59,0	1200	200



optional



Steel frame dolly with 2  
angle-steel frames  
REF 161TA6551



Steel frame dolly with 2  
angle-steel frames  
REF 161TA6549

## Steel frame dollies with 2 angle-steel frames, 1200kg carrying capacity

161TA6549	TR	870	670	721	800	600	40,0	500	200
161TA6550	TR	1070	870	721	1000	800	44,0	500	200
138TA4005	TR	1270	870	721	1200	800	48,0	500	200
161TA6554	TR	1270	1070	721	1200	1000	54,0	500	200

### Swivel castors with foot guards for your safety.

ER = Elastic-solid-rubber wheels TR = Thermoplastic rubber tyres

### Additional Articles

REF	Dimension	Weight
	mm	kg
161TA6723	780	Pushbar 3,5

universal for all sizes. only for combined order with steel frame dolly (welded)



Pushbar  
REF 161TA6723

### Additional Articles

REF	Dimension	Weight
	mm	kg
161TA6724	677	Shaft and Coupling 3,9

universal for all sizes. only for combined order with steel frame dolly (welded)



Shaft and Coupling  
REF 161TA6724

## Tipping unit for steel frame dolly

Robust welded steel construction; load surface of steel sheet; Basic position: horizontal position, tipping position approx. 18° to left and right; tilting movement by "foot power" by means of 2 end-mounted foot pedals with protective cap; locking in the three basic positions is by spring catch; long sides with steel lip to prevent slipping; Powder-coated RAL 5010 gentian blue; permanent surface protection; impact- and scratch- resistant

### Tipping unit for steel frame dolly

REF	Dimension			Loading surface		Weight
	mm			mm		
	a	b	c	d	e	
161TA6543	1685	870	658	1210	810	115,0



Tipping unit  
REF 161TA6543

**VARIOfit**

Typ 75



Typ 66



Typ 64



Typ 65



# Pallet converters

Pallet converters





# Pallet converters - two parts -



VARIOfit®  
The perfect form  
of transport

## Pallet converters

Robust tubular construction of welded steel – painted RAL 5012 light blue; suitable for Euro and industry pallets; Can be collapsed or folded to save space when not in use; Standard dimensions are TÜV tested; All pallet converters are available in various heights and as galvanised version



### Pallet converters Type 62, all sides closed with mesh, mesh size 100 x 100 mm

REF	Pallet dim.		Fill height	Stacking	Weight	Load cap.
	mm					
	a	b	f			
138TA4209	1200	800	400	4	13,5	1500
138TA4210	1200	800	600	4	17,5	1500
138TA4211	1200	1000	400	4	18,0	1500
138TA4212	1200	1000	600	4	21,0	1500



Pallet converter Type 62  
REF 138TA4209



### Pallet converter separation grid

REF	Dimension		Weight
	mm		
	b	f	
161TA6847	750	400	3,10
161TA6848	750	600	3,80
161TA6867	950	400	3,90
161TA6868	950	600	4,60
161TA6843	750	800	4,40
161TA6844	750	1000	5,10
161TA6845	750	1200	5,75
161TA6846	750	1600	7,60
161TA6869	950	800	5,40
161TA6870	950	1000	5,75
161TA6871	950	1200	6,50
161TA6872	950	1600	8,80

mesh size 100 x 100 mm  
only for Typ 62 and 64



### Pallet converter separation grid

REF	Dimension		Weight
	mm		
	b	f	
161TA6849	750	800 / 400	4,50
161TA6850	750	1000 / 500	5,20
161TA6851	750	1200 / 600	5,85
161TA6852	750	1600 / 800	7,70
161TA6863	950	800 / 400	5,50
161TA6864	950	1000 / 500	5,85
161TA6865	950	1200 / 600	6,60
161TA6866	950	1600 / 800	8,90

mesh size 100 x 100 mm  
only for Typ 62 and 64



consolidated



### Pallet converters Type 64, all 4 sides closed with mesh, mesh size 100 x 100 mm, one long side with fold-down upper half (1200 mm)

REF	Pallet dim.		Fill height	Stacking	Weight	Load cap.
	mm					
	a	b	f			
138TA4221	1200	800	800	4	21,0	1000
138TA4222	1200	800	1000	4	22,5	1000
138TA4223	1200	800	1200	4	26,5	750
138TA4224	1200	800	1600	3	38,5	750
138TA4225	1200	1000	800	4	21,5	1000
138TA4226	1200	1000	1000	4	25,5	1000
138TA4227	1200	1000	1200	4	31,5	750
138TA4228	1200	1000	1600	3	39,0	750



Short side wall half way  
foldable - on request



Pallet converter Type 64  
REF 138TA4221





# Pallet converters - two parts -

**VARIOfit**  
of transport  
The perfect form



Pallet converter Type 63  
REF 138TA4213

consolidated



Pallet converters Type 63, all 4 sides closed with mesh, mesh size 100 x 100 mm, except for one 1200 mm side with V-cutout

REF	Pallet dim.		Fill height	Stacking	Weight	Load cap.
	mm	mm	mm			
	a	b	f		kg	kg
138TA4213	1200	800	800	3	19,0	1000
138TA4214	1200	800	1000	3	22,0	1000
138TA4215	1200	800	1200	3	24,0	750
138TA4216	1200	800	1600	3	31,0	750
138TA4217	1200	1000	800	3	24,0	1000
138TA4218	1200	1000	1000	3	27,0	1000
138TA4219	1200	1000	1200	3	29,0	750
138TA4220	1200	1000	1600	3	32,5	750

Organization in the warehouse

before



after



consolidated

Pallet converter with clamping device Type 65 K

Pallet converter for subsequent fitting to loaded pallet; Frame parts secured by manual clamping function; Do not move when stacked!

for subsequent fitting



Pallet converters Type 65 K

REF	Pallet dim.		Fill height	Stacking	Weight	Load cap.
	mm	mm	mm			
	a	b	f		kg	kg
161TA6637	1200	800	800	3	25,0	1500
161TA6638	1200	800	1000	3	28,0	1500
161TA6639	1200	800	1200	3	31,0	750
161TA6640	1200	800	1600	3	34,0	750
161TA6641	1200	1000	800	3	28,5	1500
161TA6642	1200	1000	1000	3	30,5	1500
161TA6643	1200	1000	1200	3	32,5	750
161TA6644	1200	1000	1600	3	36,5	750



consolidated

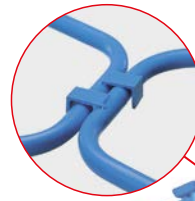

Pallet converter Type 65  
REF 138TA4229

### Pallet converters Type 65

joined and stabilised by hooking together two horizontal frames at top; The stored goods can be accessed from all sides

#### Pallet converters Type 65

REF	Pallet dim.		Fill height	Stacking	Weight kg	Load cap. kg
	mm		mm			
	a	b	f			
138TA4229	1200	800	800	3	21,5	1500
138TA4230	1200	800	1000	3	24,5	1500
138TA4231	1200	800	1200	3	27,5	750
138TA4232	1200	800	1600	3	30,5	750
138TA4233	1200	1000	800	3	25,0	1500
138TA4234	1200	1000	1000	3	27,0	1500
143TA7518	1200	1000	1200	3	29,0	750
138TA4236	1200	1000	1600	3	33,0	750



consolidated



Pallet converter Type 66  
REF 138TA4237

### Pallet converters Type 66

both long sides (1200 mm) completely open; the two ends (800 / 1000 mm) are fitted with vertical tubular bars; incl. connecting bar for stabilising the frame

#### Pallet converters Type 66

REF	Pallet dim.		Fill height	Stacking	Weight kg	Load cap. kg
	mm		mm			
	a	b	f			
138TA4237	1200	800	800	4	28,0	500
138TA6986	1200	800	1000	3	31,5	500
138TA6987	1200	800	1200	3	33,0	300
138TA6988	1200	1000	800	4	23,0	500
138TA6989	1200	1000	1000	3	33,0	500
138TA4242	1200	1000	1200	3	36,0	300





# Pallet converters - two parts -



Pallet converter Type 68  
REF 138TA4243



consolidated

## Pallet converters Type 68

All 4 sides with diagonal tubes running from bottom corners to meet at top centre

### Pallet converters Type 68

REF	Pallet dim.		Fill height	Stacking	Weight kg	Load cap. kg
	a	b	f			
138TA4243	1200	800	800	3	33,0	2000
138TA4244	1200	800	1000	3	36,5	2000
138TA4245	1200	800	1200	3	43,5	2000
138TA4246	1200	800	1600	3	45,5	2000
138TA4247	1200	1000	800	3	34,5	2000
138TA4248	1200	1000	1000	3	38,5	2000
138TA4249	1200	1000	1200	3	44,0	2000
138TA4238	1200	1000	1600	3	52,0	2000



Pallet converter Type 75  
REF 138TA4250

## Pallet converters Type 75

The two 1200-mm sides have 4 vertical tubular bars each; the two ends (800 / 1000 mm) are open

### Pallet converters Typ 75

REF	Pallet dim.		Fill height	Stacking	Weight kg	Load cap. kg
	a	b	f			
138TA4250	1200	800	800	4	28,5	2000
138TA4251	1200	800	1000	4	31,5	2000
138TA4252	1200	800	1200	3	34,5	1000
138TA4253	1200	800	1600	3	38,5	1000
138TA4239	1200	1000	800	4	30,0	1000
138TA4240	1200	1000	1000	4	33,0	1000
138TA4254	1200	1000	1200	3	35,5	500
138TA4255	1200	1000	1600	3	41,0	500



# Pallet converters - two parts - galvanised



## Pallet converter - galvanised -

Robust tubular construction of welded steel – galvanised; Suitable for Euro and industry pallets; can be collapsed or folded to save space when not in use; standard dimensions are TUV tested; All pallet converters are available in various heights



consolidated



### Pallet converters Type 62, all sides closed with mesh, mesh size 100 x 100 mm

REF	Pallet dim.		Fill height	Stacking	Weight	Load cap.
	mm		mm			
	a	b	f		kg	kg
161TA6567	1200	800	400	4	13,5	1500
161TA6568	1200	800	600	4	17,5	1500
161TA6587	1200	1000	400	4	18,0	1500
161TA6588	1200	1000	600	4	21,0	1500



Pallet converter Type 62  
REF 161TA6567



### Pallet converters separation grid

REF	Dimension		Weight
	mm		
	b	f	
161TA6857	750	400	3,10
161TA6858	750	600	3,80
161TA6877	950	400	3,90
161TA6878	950	600	4,60
161TA6853	750	800	4,40
161TA6854	750	1000	5,10
161TA6855	750	1200	5,75
161TA6856	750	1600	7,60
161TA6879	950	800	5,40
161TA6880	950	1000	5,75
161TA6881	950	1200	6,50
161TA6882	950	1600	8,80

mesh size 100 x 100 mm  
only for Typ 62 and 64



### Pallet converters separation grid

REF	Dimension		Weight
	mm		
	b	f	
161TA6859	750	800 / 400	4,50
161TA6860	750	1000 / 500	5,20
161TA6861	750	1200 / 600	5,85
161TA6862	750	1600 / 800	7,70
161TA6873	950	800 / 400	5,50
161TA6874	950	1000 / 500	5,85
161TA6875	950	1200 / 600	6,60
161TA6876	950	1600 / 800	8,90

mesh size 100 x 100 mm  
only for Typ 62 and 64



consolidated



### Pallet converters Type 64, all 4 sides closed with mesh, mesh size 100 x 100 mm, one long side with fold-down upper half (1200 mm)

REF	Pallet dim.		Fill height	Stacking	Weight	Load cap.
	mm		mm			
	a	b	f		kg	kg
138TA4256	1200	800	800	4	21,0	1000
138TA4257	1200	800	1000	4	22,5	1000
138TA4258	1200	800	1200	4	26,5	750
138TA4259	1200	800	1600	3	38,5	750
161TA6593	1200	1000	800	4	21,5	1000
161TA6594	1200	1000	1000	4	25,5	1000
161TA6595	1200	1000	1200	4	31,5	750
161TA6596	1200	1000	1600	3	39,0	750



Short side wall half way  
foldable - on request



Pallet converter Type 64  
REF 138TA4256



\*similar to figure



# Pallet converters - two parts - galvanised



Pallet converter Type 63  
REF 161TA6569



consolidated

Pallet converters Type 63, all 4 sides closed with mesh, mesh size 100 x 100 mm, except for one 1200 mm side with V-cutout.

REF	Pallet dim.		Fill height	Stacking	Weight kg	Load cap. kg
	a	b	f			
161TA6569	1200	800	800	3	19,0	1000
161TA6570	1200	800	1000	3	22,0	1000
161TA6571	1200	800	1200	3	24,0	750
161TA6572	1200	800	1600	3	31,0	750
161TA6589	1200	1000	800	3	24,0	1000
161TA6590	1200	1000	1000	3	27,0	1000
161TA6591	1200	1000	1200	3	29,0	750
161TA6592	1200	1000	1600	3	32,5	750

## Organization in the warehouse

before



after



consolidated

**Pallet converter with clamping device Type 65 K**  
Pallet converter for subsequent fitting to loaded pallet;  
Frame parts secured by manual clamping function;  
**Do not move when stacked!**

for subsequent fitting



Pallet converter Type 65 K  
REF 161TA6694

\*similar to figure



\*similar to figure

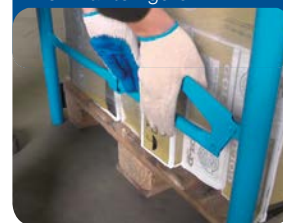

## Pallet converters Type 65 K galvanised

REF	Pallet dim.		Fill height	Stacking	Weight kg	Load cap. kg
	a	b	f			
161TA6694	1200	800	800	3	25,0	1500
161TA6695	1200	800	1000	3	28,0	1500
161TA6696	1200	800	1200	3	31,0	750
161TA6697	1200	800	1600	3	34,0	750
161TA6745	1200	1000	800	3	28,5	1500
161TA6746	1200	1000	1000	3	30,5	1500
161TA6747	1200	1000	1200	3	32,5	750
161TA6748	1200	1000	1600	3	36,5	750





consolidated

### Pallet converters Type 65

joined and stabilised by hooking together two horizontal frames at top; The stored goods can be accessed from all sides

#### Pallet converters Type 65 galvanised

REF	Pallet dim.		Fill height	Stacking	Weight	Load cap.
	mm		mm			
	a	b	f		kg	kg
138TA4260	1200	800	800	3	21,5	1500
138TA4261	1200	800	1000	3	24,5	1500
138TA4262	1200	800	1200	3	27,5	750
138TA4263	1200	800	1600	3	30,5	750
161TA6573	1200	1000	800	3	25,0	1500
161TA6597	1200	1000	1000	3	27,0	1500
161TA6574	1200	1000	1200	3	29,0	750
161TA6575	1200	1000	1600	3	33,0	750



Pallet converter Type 65  
REF 138TA4260



consolidated

### Pallet converters Type 66

both long sides (1200 mm) completely open; the two ends (800 / 1000 mm) are fitted with vertical tubular bars; incl. connecting bar for stabilising the frame

#### Pallet converters Type 66 galvanised

REF	Pallet dim.		Fill height	Stacking	Weight	Load cap.
	mm		mm			
	a	b	f		kg	kg
161TA6556	1200	800	800	4	28,0	500
161TA6557	1200	800	1000	3	31,5	500
161TA6558	1200	800	1200	3	33,0	300
161TA6576	1200	1000	800	4	30,0	500
161TA6577	1200	1000	1000	3	33,0	500
161TA6578	1200	1000	1200	3	36,0	300



Pallet converter Type 66  
REF 161TA6556



\*similar to figure



# Pallet converters - two parts - galvanised



Pallet converter Type 68  
REF 161TA6559



consolidated

## Pallet converters Type 68

All 4 sides with diagonal tubes running from bottom corners to meet at top centre

### Pallet converters Type 68 galvanised

REF	Pallet dim.		Fill height	Stacking	Weight	Load cap.
	a	b	f		kg	kg
161TA6559	1200	800	800	3	33,0	2000
161TA6560	1200	800	1000	3	36,5	2000
161TA6561	1200	800	1200	3	43,5	2000
161TA6562	1200	800	1600	3	45,5	2000
161TA6579	1200	1000	800	3	34,5	2000
161TA6580	1200	1000	1000	3	38,5	2000
161TA6581	1200	1000	1200	3	44,0	2000
161TA6582	1200	1000	1600	3	52,0	2000



Pallet converter Type 75  
REF 161TA6563



## Pallet converters Type 75

The two 1200-mm sides have 4 vertical tubular bars each; the two ends (800 / 1000 mm) are open

### Pallet converters Type 75 galvanised

REF	Pallet dim.		Fill height	Stacking	Weight	Load cap.
	a	b	f		kg	kg
161TA6563	1200	800	800	4	28,5	2000
161TA6564	1200	800	1000	4	31,5	2000
161TA6565	1200	800	1200	3	34,5	1000
161TA6566	1200	800	1600	3	38,5	1000
161TA6583	1200	1000	800	4	30,0	1000
161TA6584	1200	1000	1000	4	33,0	1000
161TA6585	1200	1000	1200	3	35,5	500
161TA6586	1200	1000	1600	3	41,0	500



Dolly collector



## Dollies

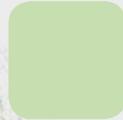

VARIOfit®



# Dollies



## Dollies

with non-slip covering; 4 swivel castors with plastic or thermoplastic rubber tyres with precision deep-groove ball bearings; Carrying capacity up to 900 kg; All dolly products are available in packaging units of 2 dollies



Dolly  
REF 161TA6635



Dolly  
REF 161TA6636



Dolly  
REF 163TA7885



Dolly  
REF 161TA6413



Dolly  
REF 161TA6412



Dolly  
REF 161TA6779



Dolly  
REF 161TA6780

### Dolly with plastic swivel castors

REF	Dimension			Loading surface		Weight	Load cap.	Wheel diam.
	a	b	c	d	e			
161TA6635	600	600	176	600	600	10,3	900	125

packaging units of 2 dollies



### Dolly with thermoplastic rubber swivel castors

REF	Dimension			Loading surface		Weight	Load cap.	Wheel diam.
	a	b	c	d	e			
161TA6636	600	600	253	600	600	11,9	750	200

packaging units of 2 dollies



### Dollies with plastic swivel castors

REF	Dimension			Loading surface		Weight	Load cap.	Wheel diam.
	a	b	c	d	e			
163TA7885	600	350	145	600	350	5,5	500	100
161TA6226	600	350	175	600	350	6,5	500	125
161TA6416	600	300	145	600	300	5,0	500	100

packaging units of 2 dollies



### Dollies with thermoplastic rubber swivel castors - Premium -

REF	Dimension			Loading surface		Weight	Load cap.	Wheel diam.
	a	b	c	d	e			
161TA6413	600	350	145	600	350	5,5	350	100
161TA6784	600	350	175	600	350	6,5	350	125
161TA6414	600	300	145	600	300	5,0	350	100

packaging units of 2 dollies

### Dollies with thermoplastic rubber swivel castors

REF	Dimension			Loading surface		Weight	Load cap.	Wheel diam.
	a	b	c	d	e			
163TA7886	600	350	145	600	350	6,0	300	100
161TA6227	600	350	175	600	350	7,0	300	125
161TA6412	600	300	145	600	300	5,5	300	100

packaging units of 2 dollies

### Dollies with plastic swivel castors (grooved rubber mat bonded to load surface)

REF	Dimension			Loading surface		Weight	Load cap.	Wheel diam.
	a	b	c	d	e			
161TA6779	600	350	145	600	350	5,5	500	100
161TA6782	600	350	175	600	350	6,5	500	125
161TA6785	600	300	145	600	300	5,0	500	100

packaging units of 2 dollies

### Dollies with thermoplastic tyres swivel castors (grooved rubber mat bonded to load surface)

REF	Dimension			Loading surface		Weight	Load cap.	Wheel diam.
	a	b	c	d	e			
161TA6780	600	350	145	600	350	6,0	300	100
161TA6783	600	350	175	600	350	7,0	300	125
161TA6781	600	300	145	600	300	5,5	300	100

packaging units of 2 dollies



# Triple-Dogs / Dollies Europa / Dolly collector

## Triple-Dogs

Multiplex plywood; 3 swivel castors with plastic or thermoplastic rubber tyres with precision deep-groove ball bearings; Carrying capacity 200 to 300 kg; All dolly products are available in packaging units of 2 dollies



### Triple-Dog with plastic swivel castors

REF	Dimension			Loading surface		Weight	Load cap.	Wheel diam.
	mm			mm				
	a	a	c	d	e			
161TA6220	540	540	145	540	540	3	300	100

packaging units of 2 dollies

Customized dollies on request.

### Triple-Dog with thermoplastic tyres swivel castors

REF	Dimension			Loading surface		Weight	Load cap.	Wheel diam.
	mm			mm				
	a	a	c	d	e			
161TA6220	540	540	145	540	540	3,5	200	100

packaging units of 2 dollies

## Dollies Europa

Multiplex plywood with rubber buffer; surround as additional collision protection for walls and doors; 4 swivel castors with plastic or solid-rubber, grey non-marking, with roller bearings; or thermoplastic rubber tyres with precision deep-groove ball bearings; Carrying capacity up to 500 kg; All dolly products are available in packaging units of 2 dollies

### Dolly Europa with plastic swivel castors

REF	Dimension			Loading surface		Weight	Load cap.	Wheel diam.
	mm			mm				
	a	b	c	d	e			
163TA7887	600	350	145	600	350	5,5	500	100

packaging units of 2 dollies

### Dolly Europa with thermoplastic tyres swivel castors - Premium -

REF	Dimension			Loading surface		Weight	Load cap.	Wheel diam.
	mm			mm				
	a	b	c	d	e			
161TA6415	600	350	145	600	350	6,0	300	100

packaging units of 2 dollies

### Dolly Europa with thermoplastic tyres swivel castors

REF	Dimension			Loading surface		Weight	Load cap.	Wheel diam.
	mm			mm				
	a	b	c	d	e			
163TA7888	600	350	145	600	350	6,5	300	100

packaging units of 2 dollies

## Dolly collector

Welded steel construction; For approx. 40 dollies measuring 600 x 300 mm or 600 x 350 mm; Powder-coated RAL 5010 gentian blue; permanent surface protection; impact- and scratch-resistant; with four 125 mm plastic swivel castors

Dolly collector on request.

### Dolly collector for 600mm x 300mm und 600mm x 350mm

REF	Dimension			Loading surface	Weight	Load cap.	Wheel diam.
	mm						
	a	b	c				
147TA3372	700	720	2000	40x	22,0	250	125

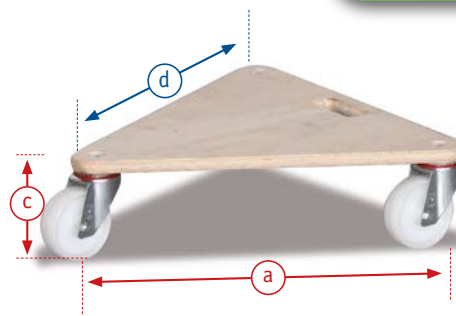

Triple-Dog  
REF 161TA6220



Triple-Dog  
REF 161TA6221



Dolly Europa  
REF 163TA7887



Dolly Europa  
REF 161TA6415



Dolly Europa  
REF 163TA7888

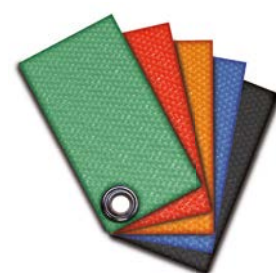

Dolly collector  
REF 147TA3372

**VARIOfit**<sup>®</sup>



**Bridge plate**



**Ramp**



# Bridge plate / Ramp

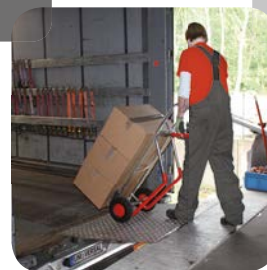

**Bridge plate**  
Sheet aluminium for loading and unloading vehicles

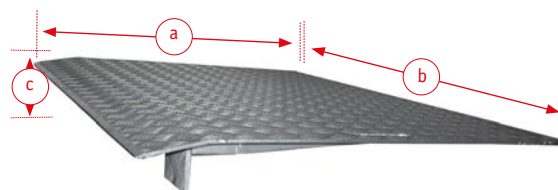

**Bridge plate**

REF	Dimension			Weight	Load cap.
	mm				
	a	b	c		
139TA3153	1000	1250	120	35,0	1200

Bridge plate  
REF 139TA3153

**Ramp**

Ramp with movable lip for driving lift trucks into sea containers;  
The entire area of the ramp is resting on the ground when the lift truck drives in; it rises from 0 to 200 mm; height under the lip 190 mm; Steel construction with safety-tread steel plate 6/8 mm for the ramp; with flat-steel reinforcement at rear; lip 10/12 mm at front, angled at 10°; With retractable lifting stirrup for transporting the ramp by lift truck; all 4 corners bevelled; chain with hook on both sides to prevent shifting; Colour: Industrial paint, black



**Ramp with movable lip**

REF	Dimension			Lip Depth	Weight	Load cap.
	mm					
	a	b	c			
139TA3154	2000	1800	200	300	150,0	7500

Ramp  
REF 139TA3154



# Index



<b>A</b>		
add-on row for starter unit	17	
Add-on frame for pallet dolly	105	
pallet dolly	27, 31, 33, 38 - 40	
additional tray	37, 38	
aluminium	15, 18, 30, 74, 77 - 80, 82	
aluminium truck	74, 77 - 79, 80	
anti-slip	16, 18, 21, 22, 29, 41, 55, 60, 68, 69, 84	
antistatic	9, 26, 27	
appliance trucks	83, 84	
<b>B</b>		
ball socket	102, 103	
bicycle trailers	97	
board-sided box trolley	24, 25	
book trolley	44	
box trolley	23, 24	
bridge plate	119	
<b>C</b>		
c+c trolley	16	
c+c trolley security	17	
cabinet with drawers	46 - 51	
carrier-spar trolley	60	
clamping device	108	
cleaning trolley	94	
chair truck	80	
central locking system	46 - 51	
clipboard	9	
coin lock	17	
corrugated bracket	58	
coupling	97, 100 - 103	
crate dolly	68	
cupboards	46 - 51	
cushion rubber tyre	74	
cylinder trolley	87	
<b>D</b>		
dead man's brake	7, 34, 35, 85	
distance piece	73	
document trolley	42 - 44	
dolly	116	
dolly "Europa"	117	
dolly collector	117	
double-end pushbar trolley	14, 15	
double-end trolley	19 - 22	
drain cock	10, 53, 92, 93, 95	
drawbar eye	97, 100, 101	
drawer	28, 46 - 51	
drawer divider set	10, 51	
drip tray	52, 53, 92, 93	
drive-in plate	119	
drum dispenser	91	
drum dolly	90	
drum trolley	93	
drum truck	89 - 90	
<b>E</b>		
EasySTOP	7, 10, 12, 14, 15, 18 - 21, 23 - 41, 44, 46 - 53, 56, 58, 63, 66, 67, 104, 105	
EasySTOP NO surcharge	7, 15, 18, 36, 41, 44, 46, 47, 52, 63	
elastic solid-rubber wheels	9, 21, 22, 29, 57, 69, 102, 105	
electrically conductive (ESD)	8, 9, 26, 27	
Environmentally	53, 91 - 95	
euro container trolley	61, 62	
euro size containers	10, 61 - 63, 66	
euro system dolly	67	
extension tube	73	
extras	9 - 11	
<b>F</b>		
feet	73	
folding toe	79	
folding trolley	15	
forked bracket	58	
four-axle turntable steering	100	
four-sided trolley	19 - 22, 31, 33	
<b>G</b>		
galvanised	9, 10, 29, 36, 40, 41, 46, 51, 58, 71 - 73, 92, 93, 111 - 114	
galvanised steel load surfaces	9, 29	
gas pressure spring	10	
glass	41	
grating	53, 92, 93	
<b>H</b>		
hand trolley	97 - 98	
hand truck	97	
hang-on wire basket	10	
heavy-duty trolley	21, 22, 26, 29, 49, 94 - 102	
hinged door	36, 46 - 51	
<b>I</b>		
industrial trailer	100, 101	
<b>L</b>		
lightweight folding truck	87	
lifting rings	103 - 105	
load-bearing spars	11, 84	
locating cups	102, 103	
lock	23, 28, 36, 43, 46 - 51	
long-goods dolly	69	
long-goods trolley	69	
<b>M</b>		
material box	10, 58	
material crate	10, 58	
material stand	64	





since 2011

The central foot brake



TVH PARTS NV  
Brabantstraat 15 · 8790 Waregem · Belgium  
T +32 56 43 42 11 · F +32 56 43 44 88  
parts@tvh.com · www.tvh.com

**TVH PARTS**

